



WEIGHT BENCH WITH 40KG SET

USER MANUAL



IMPORTANT

Read all instructions carefully before using this product. Retain this owner's manual for future reference. The specifications of this product may vary and are subject to change without further notice.



BEFORE YOU BEGIN

Thank you for choosing Gymstick training equipment. We take great pride in producing this high-quality product and hope it will make you feel better and enjoy life to the fullest. Please read this manual in its entirety before beginning to use this product.



IMPORTANT

Read all instructions carefully before using this product.
Retain this owner's manual for future reference.



WARNING

Read and follow all safety instructions carefully.
Failure to follow safety instructions could result in serious injury.

BEFORE YOU BEGIN	2
SAFETY INSTRUCTIONS	3
HARDWARE PACKING LIST	4
ASSEMBLY	6
WARM UP & COOL DOWN	16
EXPLODED DRAWING	18
PARTS LIST	19
CLEANING & STORAGE	19
IMPLIED WARRANTY	20



IMPORTANT

Before assembly, please ensure all parts are included in the package.
In case any parts are missing, contact our customer service to resolve the issue.

SAFETY INSTRUCTIONS

Basic precautions should always be followed when using this product. In order to ensure safe read and follow all safety instructions included in this user manual. Failure to do so could result in serious injury.









WARNING

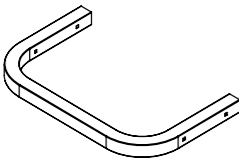
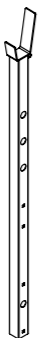
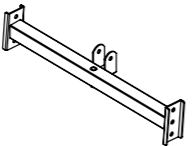
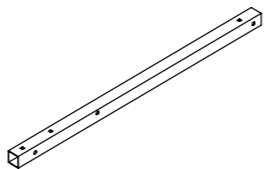
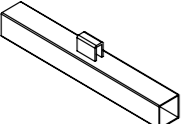
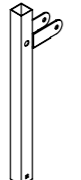
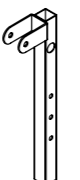
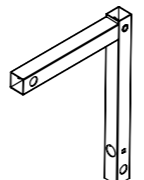
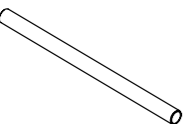
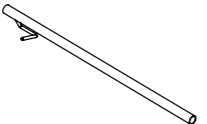
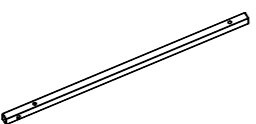
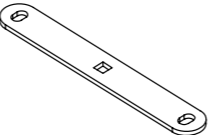
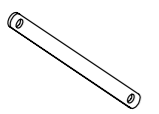
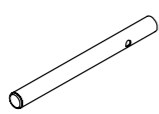

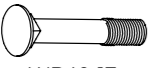
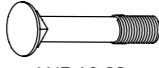

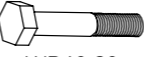
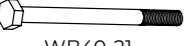

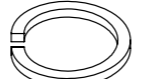

Before using this product, consult your physician first. This is especially important for individuals over the age of 35 or persons with pre-existing health problems.

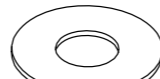
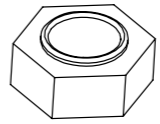
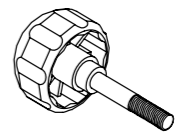
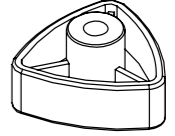
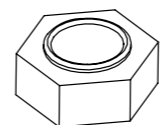
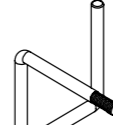
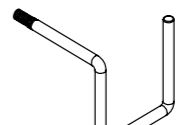
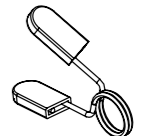
1. This product is not a toy. Keep children and pets away from the device at all times. Do not leave unattended children in the same room with the device.
2. Handicapped or disabled persons should not use the device without the presence of a qualified health care professional or physician.
3. If the user experiences dizziness, nausea, chest pain, or any other abnormal symptoms, stop the workout at once. Consult a physician immediately.
4. Before beginning training, remove all objects within a radius of 2 meters from the device. Do not place any sharp objects around the device.
5. Position the device on a clear, level surface away from water and moisture. It is suggested to place a mat under the unit to help keep the device stable and to protect the floor.
6. Only use the device for its intended purpose. Do not use any other accessories than the ones recommended by the manufacturer.
7. Assemble the device exactly as in the description in this instruction manual.
8. Check all bolts and other connections before using the device for the first time and ensure that the device is in good and safe condition.
9. Hold a routine inspection of the equipment. Pay special attention to components which are the most susceptible for wear and tear. Any defective components should be replaced immediately before using the device.
10. Never operate the device if it is not functioning properly.
11. This device can be used for only one person's training at a time.
12. Do not use abrasive cleaning articles to clean the device. Wipe drops of sweat from the device immediately after finishing training.
13. Always wear appropriate workout clothing when exercising. Running or aerobic shoes are also suggested.
14. Before exercising, always warm-up your body thoroughly by dynamic stretching our a warm-up routine.
15. This device is intended for home use.
16. This device must be assembled by adults.
17. It is the responsibility of the owner to ensure that all users are properly informed as how to use this product safely.
18. Maximum user weight 100 kg / Maximum weight load 80 kg

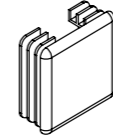
HARDWARE PACKING LIST

 WB40-01 Rear Stabilizer 1pc	 WB40-02 Upright 2pcs	 WB40-03 Cross Support 1pc	 WB40-04 Main Frame 1pc
 WB40-05 Front Stabilizer 1pc	 WB40-06 Leg Extension Upright 1pc	 WB40-07 Leg Extension Support 1pc	 WB40-08 Leg Extension 1pc
 WB40-09 Foam Roller Post 3pcs	 WB40-10 Backrest Adjustment Rod 1pc	 WB40-11 Backrest Support 2pcs	 WB40-12 Seat Backrest 1pc
 WB40-13 Stabilizer Bracket 2pcs	 WB40-14 Weight Disc Post 1pc	 WB40-15 Bolt (M6 x 14mm) 2pc	 WB40-16 Bolt (M6 x 40mm) 4pcs
 WB40-17 Carriage Bolt (M8 x 50mm) 8pcs	 WB40-18 Carriage Bolt (M8 x 55mm) 1pc	 WB40-19 Carriage Bolt (M8 x 90mm) 1pc	 WB40-20 Hex Bolt (M10 x 60mm) 1pc
 WB40-21 Hex Bolt (M10 x 130mm) 1pc	 WB40-22 Flat Washer (M6) 6pcs	 WB40-23 Flat Washer (M8) 15pcs	 WB40-24 Spring Washer (M8) 2pcs

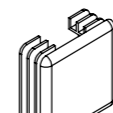
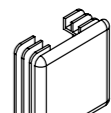
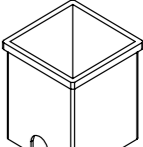
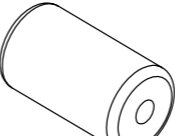
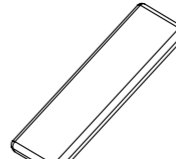
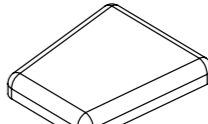
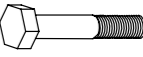
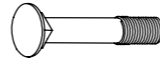
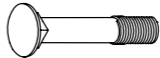
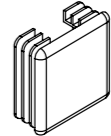
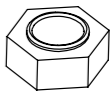
HARDWARE PACKING LIST

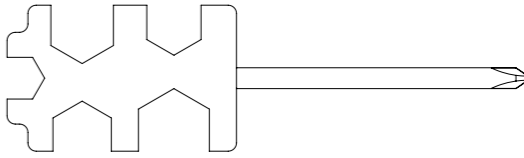
 WB40-25 Flat Washer (M10) 8pcs	 WB40-26 Nylon Locknut (M8) 13pcs	 WB40-27 Locking Knob (Male M8) 1pc	 WB40-28 Locking Knob (Female M8) 2pcs
 WB40-29 Nylon Locknut (M10) 4pcs	 WB40-30L Safety Hook (Left side) 1pc	 WB40-30R Safety Hook (Right Side) 1pc	 WB40-31 Spring Collar 1pc
 WB40-32 Backrest Support Bushing 2pcs	 WB40-33 Square End Cap (25mm) 4pcs	 WB40-34 Round End Cap (ø19mm) 8pcs	 WB40-35 Round End Cap (ø25mm) 1pc
 WB40-36 Round End Over Cap (ø25mm) 1pc	 WB40-37 Square End Cap (32mm) 2pcs	 WB40-38 Square End Cap (38mm) 6pcs	 WB40-39 Square Internal Bushing (38mm) 1pc
 WB40-40 Foam Roller 6pcs	 WB40-41 Backrest 1pc	 WB40-42 Seat 1pc	 WB40-43 Hex Bolt (M10 x 55mm) 2pcs
 WB40-44 Carriage Bolt (M8 x 85mm) 2pcs	 WB40-45 Carriage Bolt (M8 x 45mm) 3pcs	 WB40-46 Square End Cap (33.4mm) 5pcs	 WB40-47 Locknut (M6) 2pcs
 WB40-48 Washer (M6) 2pcs	 WB40-49 Tool 2pcs		

ASSEMBLY

Complete each stage in order before advancing on to the next. Assemble with nuts and bolts loose at first. Tighten all bolts and nuts after completing all assembly steps.

STEP 1.

Connect both Uprights (2) to the Cross Support (3) using four M8 x 50mm Carriage Bolts (17)

fitted from the inside as per illustration, four M8 Flat Washers (23) and four M8 Nylock Nuts (26).

#	PART NAME	QTY.
17	Carriage Bolt (M8 x 50mm)	4
23	Flat Washer (M8)	4
26	Nylock Nut (M8)	4

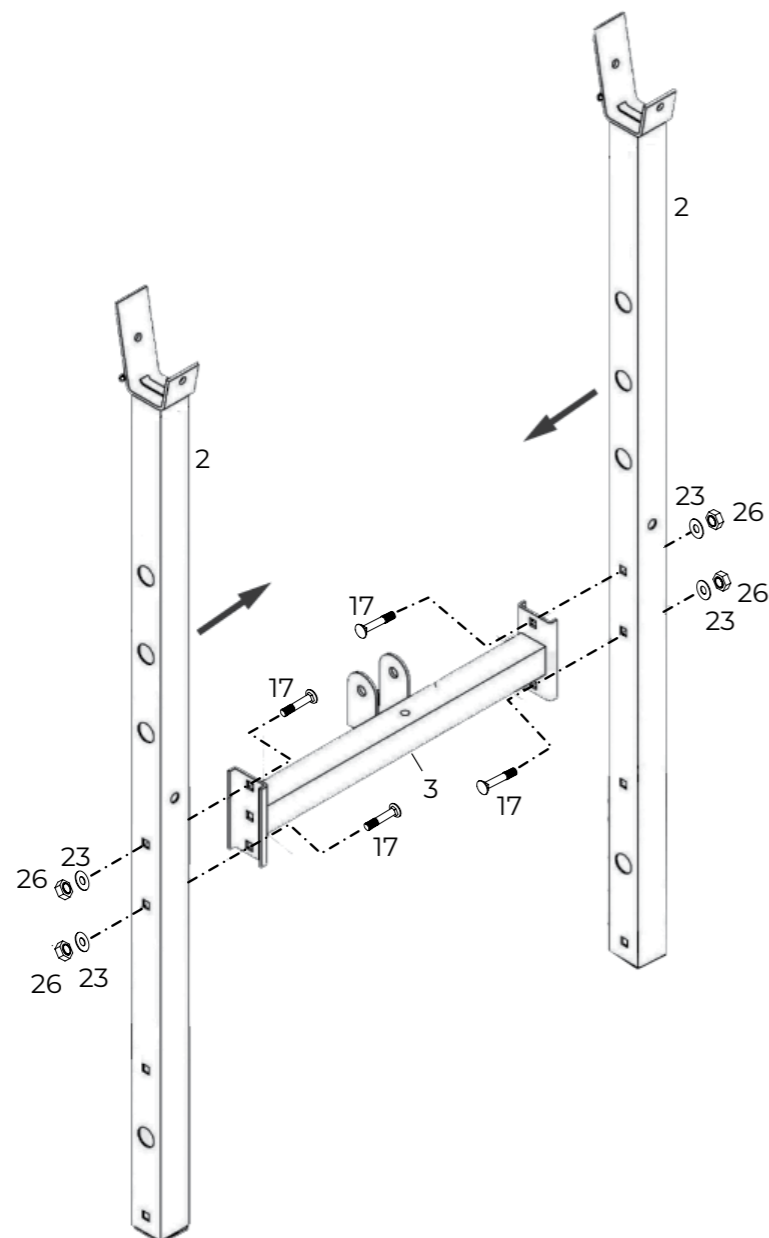

ASSEMBLY

STEP 2.

Place both Uprights (2) on the inside of the Rear Stabilizer (1) and secure in place using M8x85mm Carriage Bolts (44) fitted from the outside, M8 Flat Washers (23) and M8 NylockNuts (26).

Now attach both Stabilizer Brackets (13) to the inside of the Rear Stabilizer (1) and to the outside of both Uprights (2) using M8x50mm Carriage Bolts (17), and M8x45mm CarriageBolts (45), four M8 Flat Washers (23) and four M8 Ny-lock Nuts (26).

Attach the Safety Hook (30L & 30R) to the both Uprights (2). Using two Washers (48) and two Nylock Nuts (47). As shown.

#	PART NAME	QTY.
17	Carriage Bolt (M8x50mm)	2
23	Flat Washer (M8)	6
26	Nylock Nut (M8)	6
30R	Safety Hook	1
30L	Safety Hook	1
44	Carriage Bolt (M8x85mm)	2
45	Carriage Bolt (M8x45mm)	2
47	Nylock Nut (M6)	2
48	Washer (M)	2

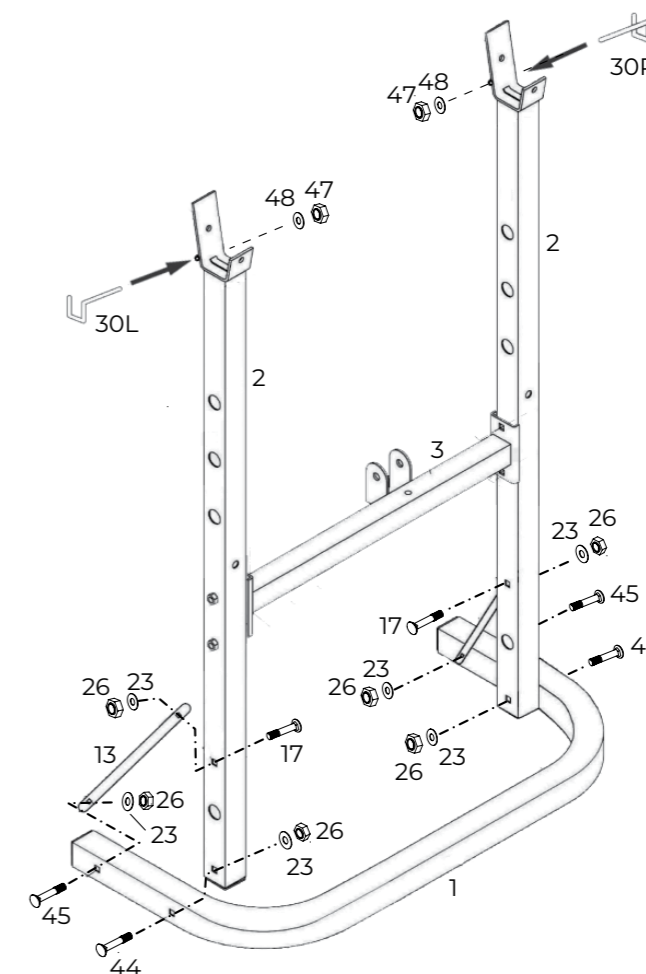

ASSEMBLY

STEP 3.

Fit the Front Stabiliser (5) to the Leg Extension Upright (6) and secure with an M8x50mm Carriage Bolt (17), an M8 Flat Washer (23) and an M8 Nylock Nut (26).

Connect the assembled Leg Extension Upright (6) to the front of the Main Frame (4) using an M10x55mm Hex Head Bolt (43), two M10 Flat Washers (25) and an M10 Nylock Nut (29) bolted from the side.

#	PART NAME	QTY.
17	Carriage Bolt (M8x50mm)	1
23	Flat Washer (M8)	1
25	Flat Washer (M10)	2
26	Nylock Nut (M8)	1
29	Nylock Nut (M10)	1
43	Hex Bolt (M10x55mm)	1

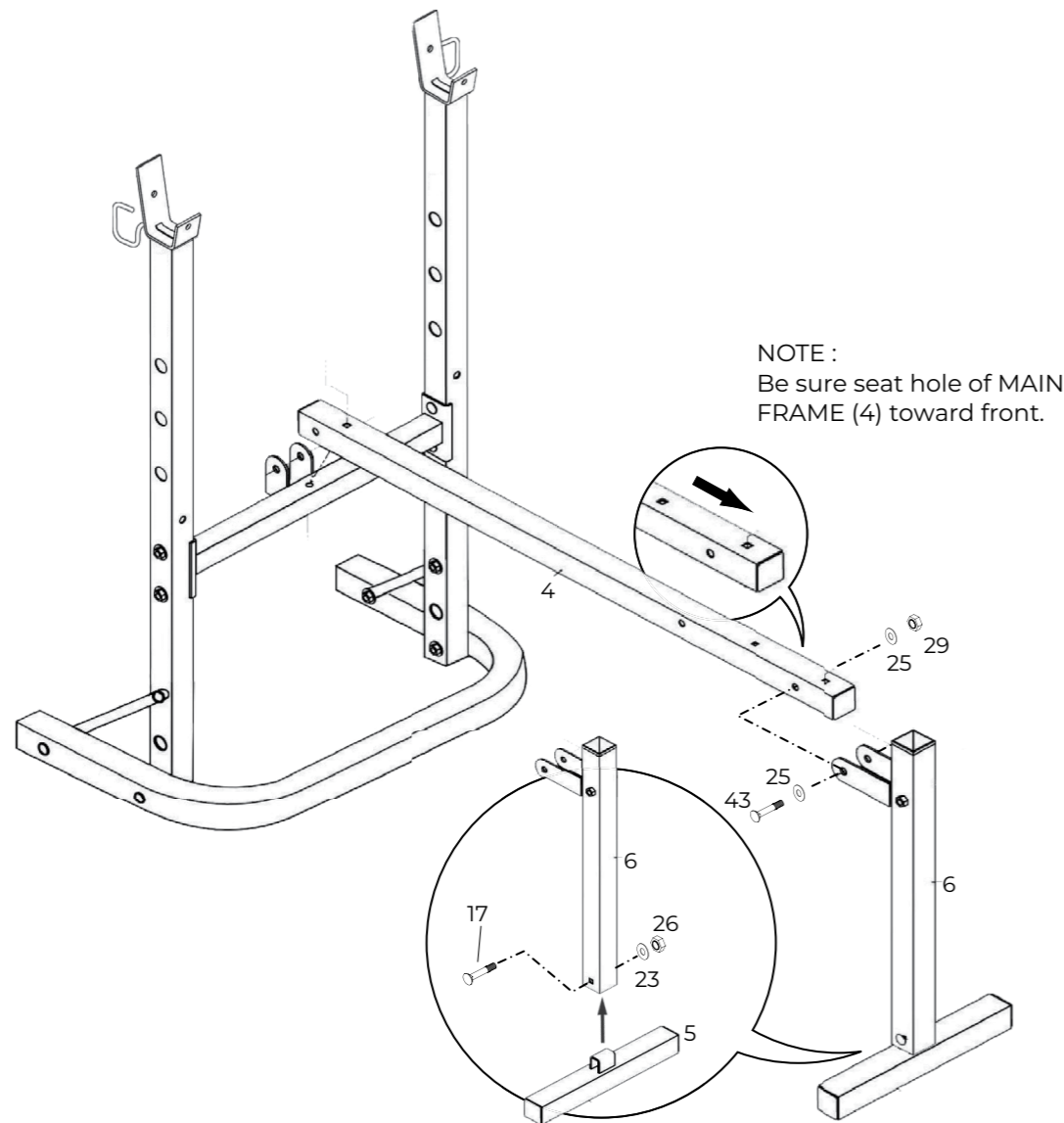

ASSEMBLY

STEP 4.

Place an M8x55mm Carriage Bolt (18) in the UPPER hole and secure in position using an M8 Flat Washer (23), an M8 Spring Washer (24) and an M8 Locking Knob (Female) (28). Tighten securely to lock the frame in position.

Connect the rear of the Main Frame (4) to the Cross Bar (3) using an M10x55mm Hex Head Bolt (43), two M10 Flat Washers (25) and an M10 Nylock Nut (29) bolted from the side.

Place an M8x90mm Carriage Bolt (19) in the upper hole and secure in position using an M8 Flat Washer (23), an M8 Spring Washer (24) and M8 Locking Knob (Female) (28). Tighten securely to lock the Main Frame (4) in position.

#	PART NAME	QTY.
18	Carriage Bolt (M8x55mm)	1
19	Carriage Bolt (M8x90mm)	1
23	Flat Washer (M8)	2
24	Spring Washer (M8)	2
25	Flat Washer (M10)	2
28	Locking Knob (Female M8)	2
29	Nylock Nut (M10)	1
43	Hex Bolt (M10 x 55mm)	1

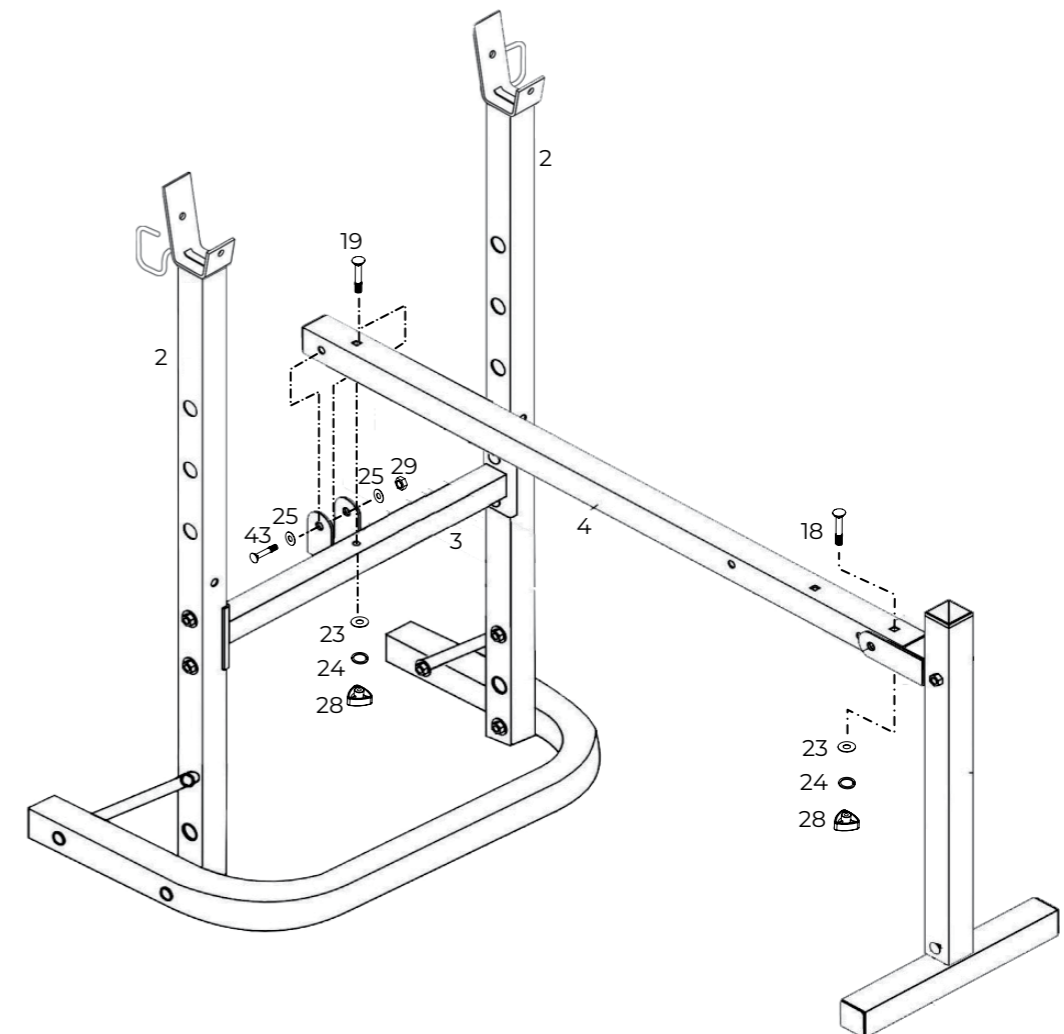

ASSEMBLY

STEP 5.

Fit the Backrest Supports (11) to the Backrest (41) using four M6x40mm Bolts (16) and four M6 Flat Washers (22).

#	PART NAME	QTY.
16	Bolt (M6 x 40mm)	4
22	Flat Washer (M6)	4

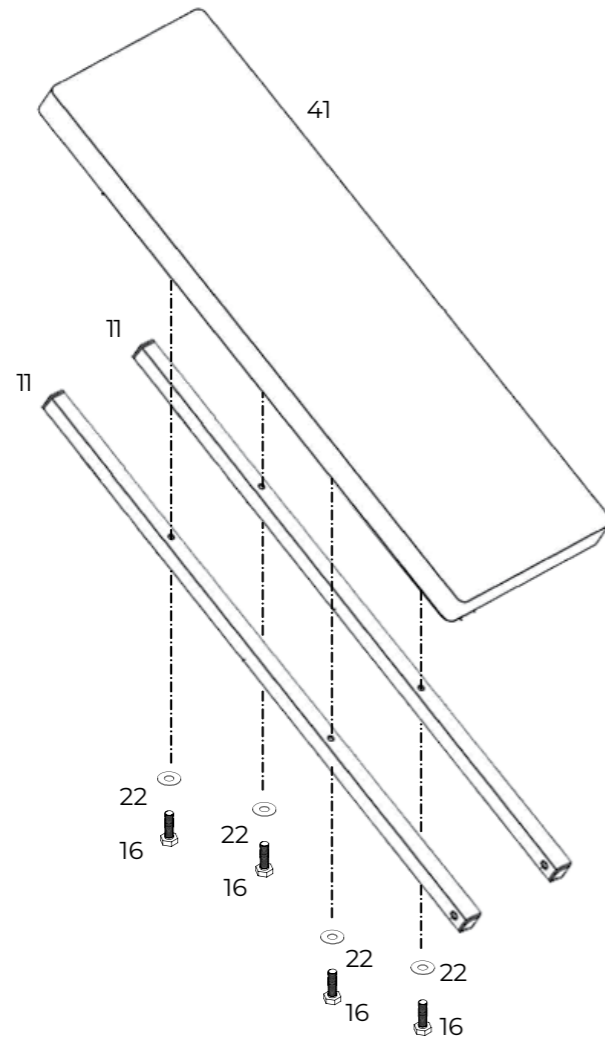

ASSEMBLY

STEP 6.

Connect the assembled Backrest (41) to the Main Frame (4) using the fittings in the following sequence. An M10x130mm Hex Bolt (21), an M10 Flat Washer (25) and an Backrest Support Bushing (32) on one side then an Backrest Support Bushing (32) on the other side of Main Frame (4), an M10 Flat Washer (25) and an M10 Nylock Nut (29). Tighten securely to remove all free-play but take care NOT to overtighten.

#	PART NAME	QTY.
21	Hex Bolt (M10 x 130mm)	1
25	Flat Washer (M10)	2
29	Nylock Nut (M10)	1
32	Backrest Support Bushing	2

Insert Backrest Adjustment Rod (10) to assembled Upright (2).

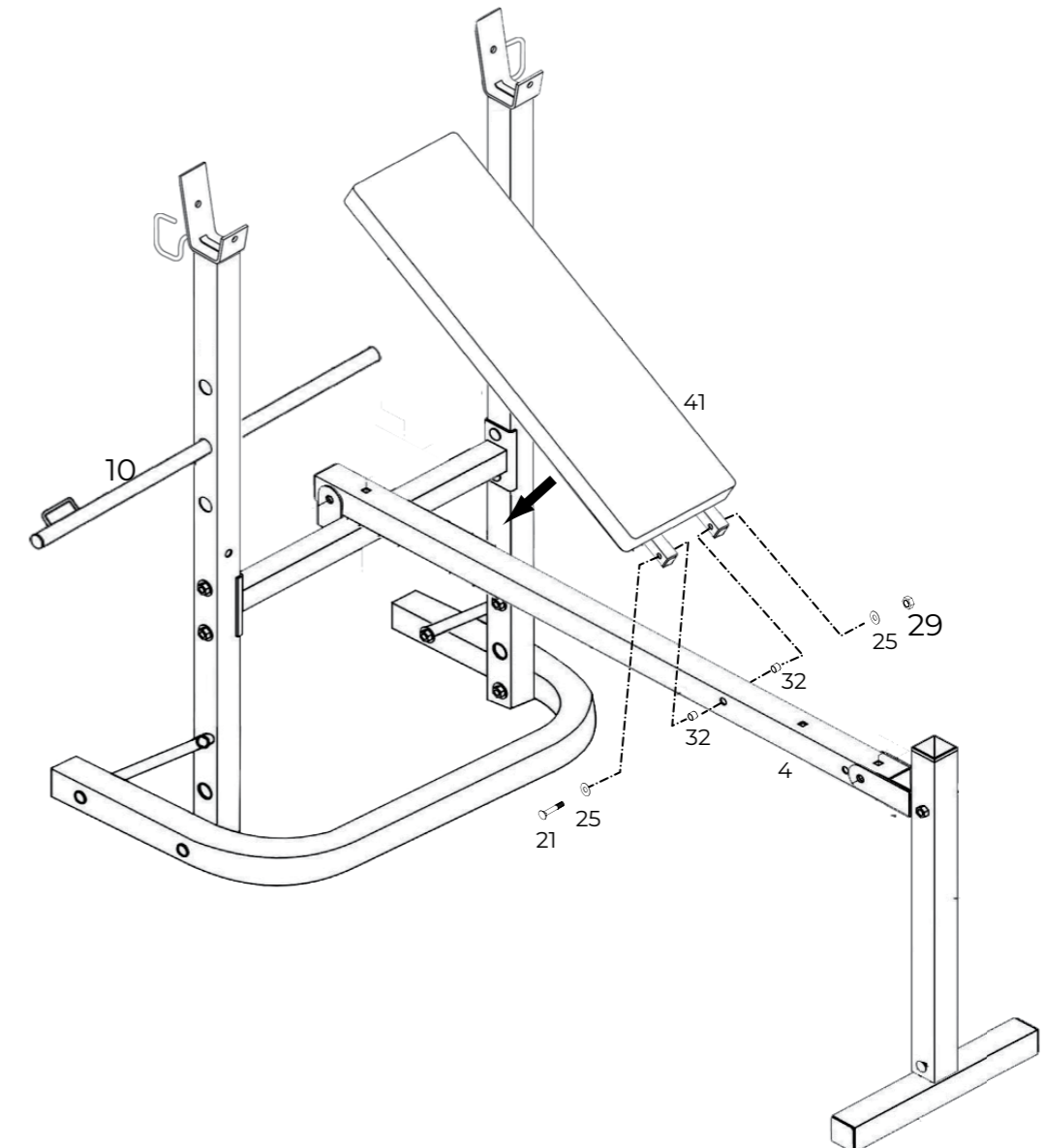

ASSEMBLY

STEP 7.

Remove the pre-fitted Seat Bracket (12) from the Seat (42). Fit the Seat Bracket (12) to the Main Frame using an M8 x 50mm Carriage Bolt (17). An M8 Flat Washer (23) and an M8 Nylock Nut (26) tightening securely.

Fit the Seat (42) to this Seat Bracket (12) using the previously removed two M6x14mm Bolts (15) and two M6 Flat Washers (22).

The Backrest can be adjusted into 4 positions for convenient use. (Flat and 3 Incline Positions). Please ensure that Backrest Adjustment Rod (10) is positioned UNDER the Backrest Supports and is secured into place in any one of the 3 adjustment holes in the Uprights before use.

#	PART NAME	QTY.
15	Bolt (M6 x 14mm)	2
17	Carriage Bolt (M8 x 50mm)	1
22	Flat Washer (M6)	2
23	Flat Washer (M8)	1
26	Nylock Nut (M8)	1

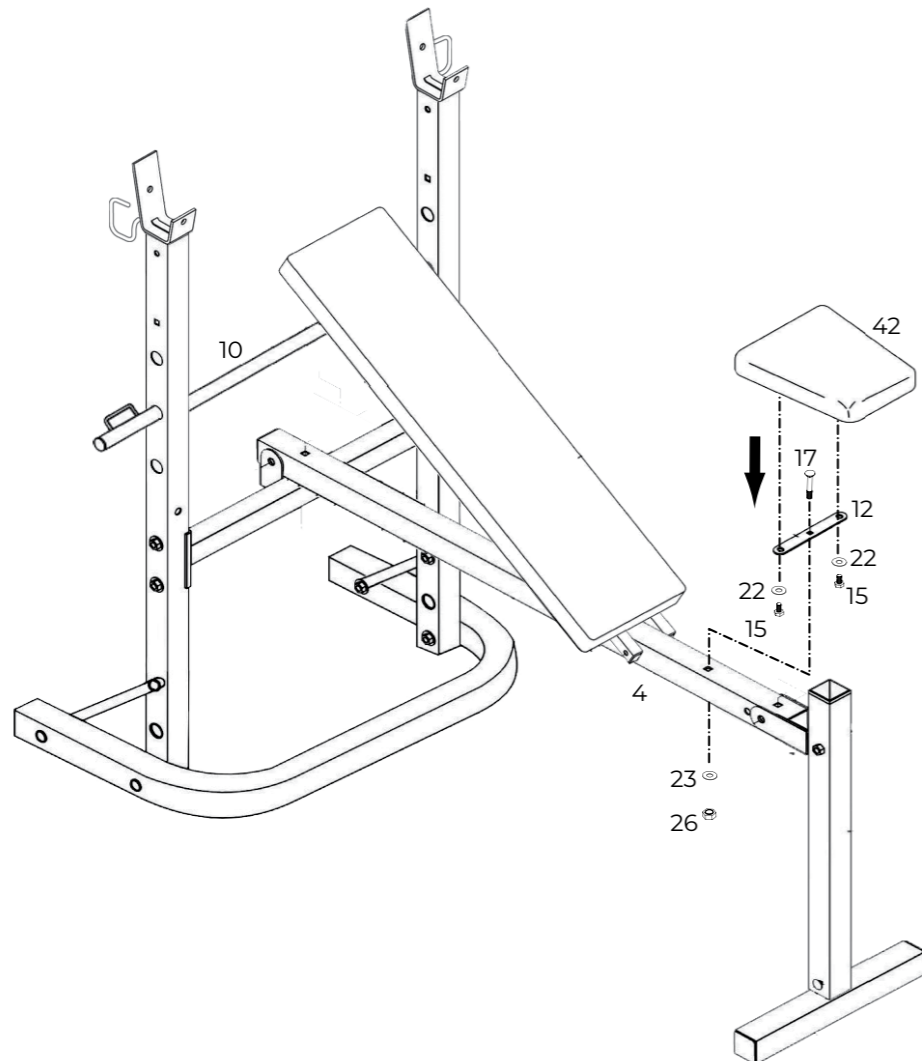

ASSEMBLY

STEP 8.

Assemble the Leg Extension (8) to the Leg Extension Support (7) using an M10x60mm Hex Bolt (20), two M10 Flat Washers (25) and an M10 Nylock Nut (29) bolted from the side.

Fit the Leg Extension Weight Disc Post (14) to the Leg Extension using an M8x48mm Carriage Bolt (45), an M8 Flat Washer (23) and an M8 Nylock Nut (26). Tighten securely and fit Spring Collar (31) by squeezing the 2 rubber pads together and sliding over end of Weight Disc Post (14).

Slide a Foam Roller (40) onto one end of a Foam Roller Post (9) and fit into position on the Leg Extension (8) and Leg Extension Support (7). Slide the remaining Foam Roller (40) onto the Foam Roller Post (9).

#	PART NAME	QTY.
20	Hex Bolt (M10 x 60mm)	1
23	Flat Washer (M8)	1
25	Flat Washer (M10)	2
26	Nylock Nut (M8)	1
29	Nylock Nut (M10)	1
31	Spring Collar	1
45	Carriage Bolt (M8 x 45mm)	1

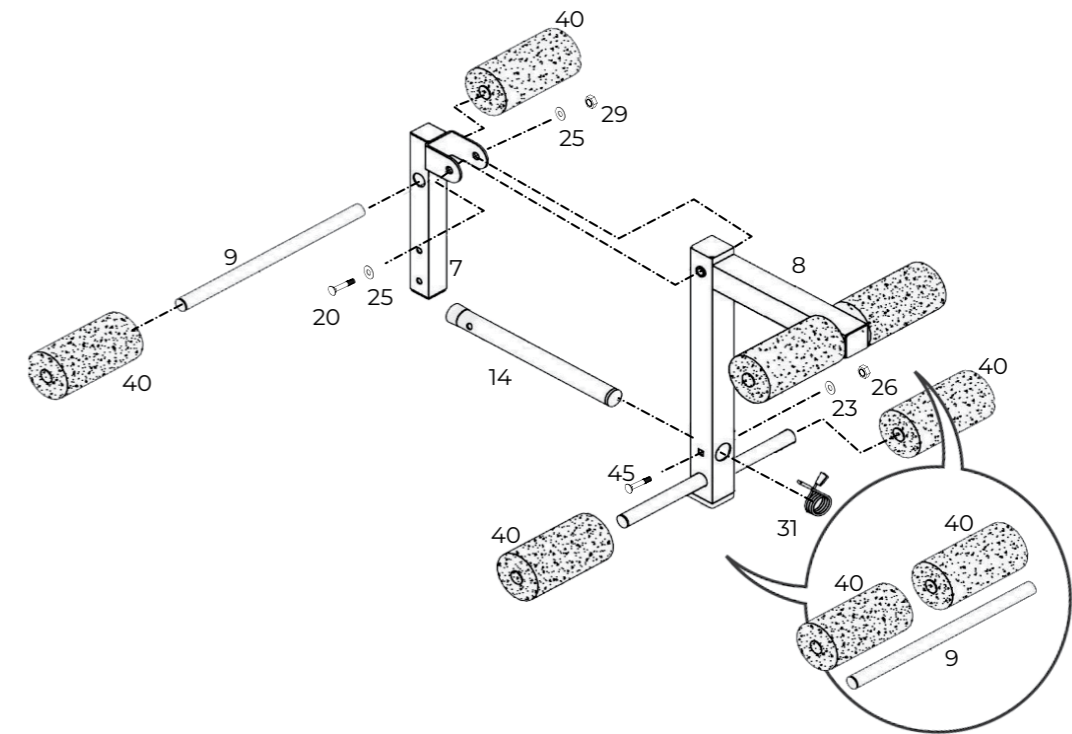

ASSEMBLY

STEP 9.

Fit Leg Extension Support (7) into the leg extension on upright to any one of 3 position and lock in position using the M8 Locking Knob (27).

#	PART NAME	QTY.
27	Locking Knob (M8)	1

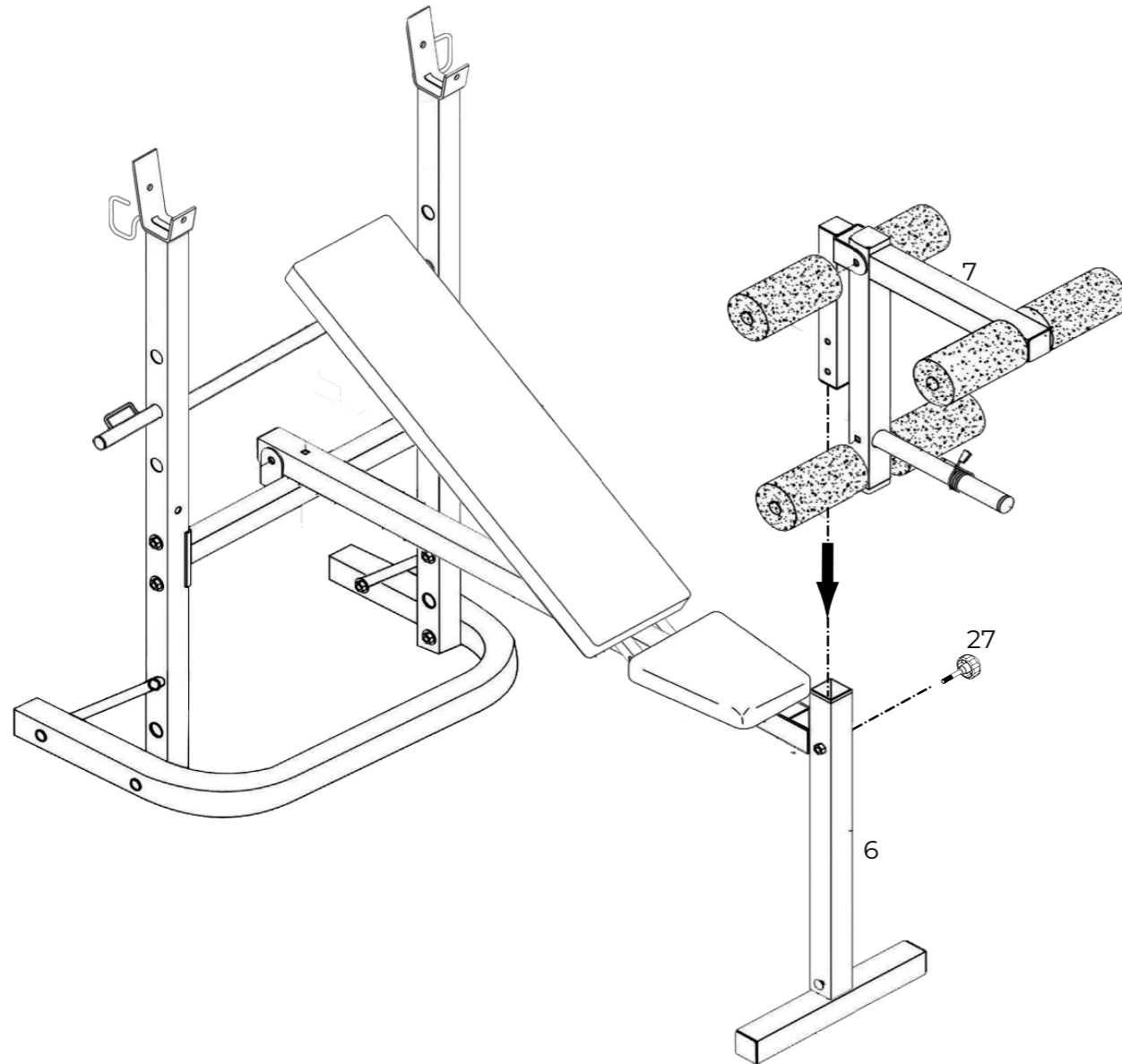

IMPORTANT

Now go back over and tight all nuts and bolts!

ASSEMBLY

STEP 10.

Before folding up the Main Frame (4), please remove Backrest Adjustment Rod (10). Re-insert Backrest Adjustment Rod (10) after Main Frame (4) is folded to keep it in place. Unscrewing the M8 Locking Knob (Male) (27) then remove the Leg Extension (7). Place this assembly to one side.

Unscrew the rear M8 Locking Knob (Female) (28) and remove the M8x90mm Carriage Bolt (19), M8 Flat Washes (23) and M8 Spring Washes (24). Lift up the Main Frame (4) to upright position.

Please do not trap your fingers in any moving parts.

Unscrew the front M8 Locking Knob (Female) (28) and remove the M8x50mm Carriage Bolt (18), M8 Flat Washer (23), and M8 Spring Washer (24) then fold down the Front Upright (6) assembly.

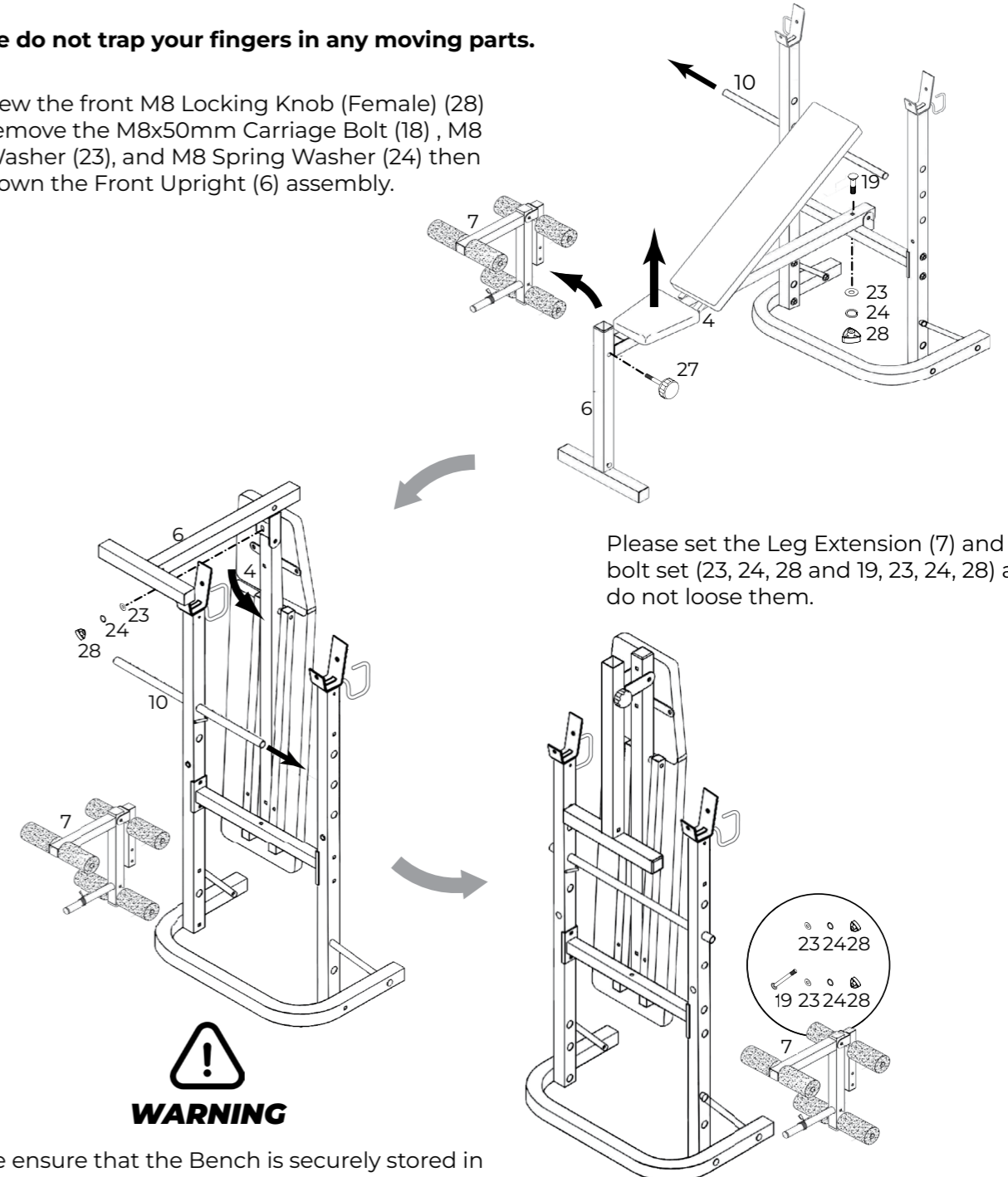

WARNING

Please ensure that the Bench is securely stored in either an upright or full flat position away from children.

WARM UP & COOL DOWN

Exercise in any form is one of the best things you can do for your overall health. A good exercise program consists of a warm-up, actual workout and a cool down.

STRENGTH TRAINING is a training form that causes your muscles to contract against an outside resistance. The resistance can be from weight machines, medicine balls, resistance bands, dumbbells or from your own body. Strength training has lots of benefits. It helps you to enhance your body composition, burn calories, improve joint flexibility, increase muscle mass and maintain a healthy body.

The WARM-UP is an important part of any workout. It should begin every session to prepare your body for more strenuous exercise by heating up and stretching your muscles, increasing your circulation and pulse rate, and delivering more oxygen to your muscles.

COOL DOWN at the end of your workout, repeat these exercises to reduce soreness in tired muscles.

Do the entire program at least two to three times a week, resting for a day between workouts. After several months you can increase your workouts to four or five times per week.



HEAD ROLLS

Rotate your head to the right for one count, feeling the stretch up the left side of your neck, then rotate your head back for one count, stretching your chin to the ceiling and letting your mouth open. Rotate your head to the left for one count, then drop your head to your chest for one count.



SHOULDER LIFTS

Lift your right shoulder toward your ear for one count. Then lift your left shoulder up for one count as you lower your right shoulder.

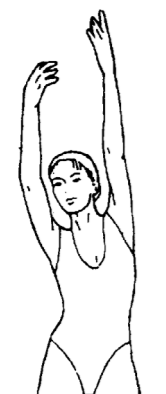

SIDE STRETCHES

Open your arms to the side and lift them until they are over your head. Reach your right arm as far toward the ceiling as you can for one count. Repeat this action with your left arm.

WARM UP & COOL DOWN



QUADRICEPS STRETCH

With one hand against a wall for balance, reach behind you and pull your right foot up. Bring your heel as close to your buttocks as possible. Hold for 15 counts and repeat with left foot.



INNER THIGH STRETCH

Sit with the soles of your feet together and your knees pointing outward. Pull your feet as close to your groin as possible. Gently push your knees toward the floor. Hold for 15 counts.



TOE TOUCHES

Slowly bend forward from your waist, letting your back and shoulders relax as you stretch toward your toes. Reach as far as you can and hold for 15 counts.



HAMSTRING STRETCHES

Extend your right leg. Rest the sole of your left foot against your right inner thigh. Stretch toward your toe as far as possible. Hold for 15 counts. Relax and then repeat with left leg.



CALF/ACHILLES STRETCH

Lean against a wall with your left leg in front of the right and your arms forward. Keep your right leg straight and the left foot on the floor; then bend the left leg and lean forward by moving your hips toward the wall. Hold, then repeat on the other side for 15 counts.

EXPLODED DRAWING

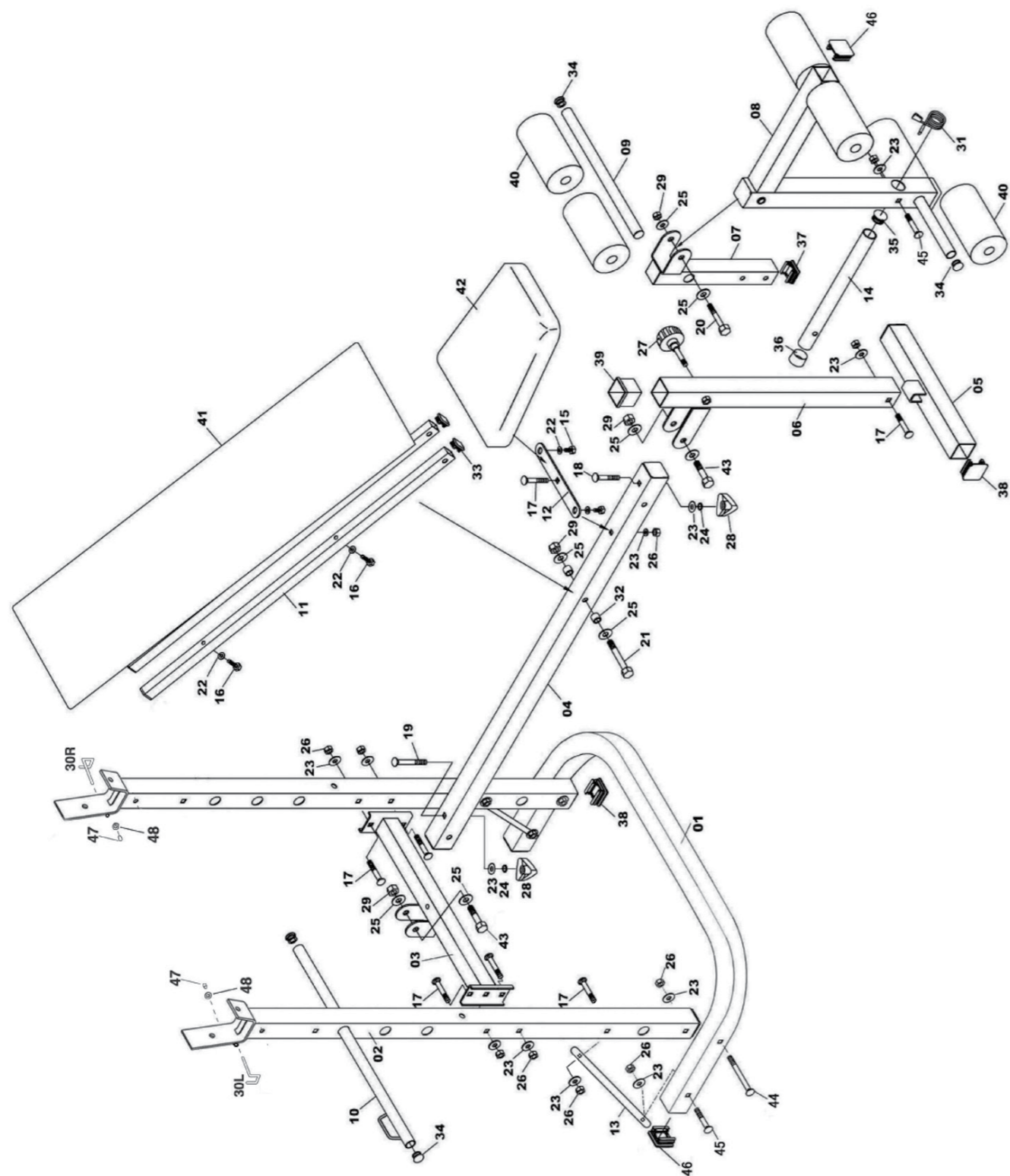

PARTS LIST

No.	Description	Qty	No.	Description	Qty
WB40-01	Rear Stabilizer	1	WB40-26	Nylon Locknut (M8)	13
WB40-02	Upright	2	WB40-27	Locking Knob (Male M8)	1
WB40-03	Cross Support	1	WB40-28	Locking Knob (Female M8)	2
WB40-04	Mainframe	1	WB40-29	Nylon Locknut (M10)	4
WB40-05	Front Stabilizer	1	WB40-30L	Safety Hook (L)	1
WB40-06	Leg Extension Upright	1	WB40-30R	Safety Hook (R)	1
WB40-07	Leg Extension Support	1	WB40-31	Spring Collar	1
WB40-08	Leg Extension	1	WB40-32	Backrest Support Bushing	2
WB40-09	Foam Roller Post	3	WB40-33	Square End Cap (25mm)	4
WB40-10	Backrest Adjustment Rod	1	WB40-34	Round End Cap (ø19mm)	8
WB40-11	Backrest Support	2	WB40-35	Round End Cap (ø25mm)	1
WB40-12	Seat Bracket	1	WB40-36	Round End Over Cap (ø25mm)	1
WB40-13	Stabilizer Bracket	2	WB40-37	Square End Cap (32mm)	2
WB40-14	Weight Disc Post	1	WB40-38	Square End Cap (38mm)	6
WB40-15	Bolt (M6 x 14mm)	2	WB40-39	Square Internal Bushing (38mm)	1
WB40-16	Bolt (M6 x 40mm)	4	WB40-40	Foam Roller	6
WB40-17	Carriage Bolt (M8 x 50mm)	8	WB40-41	Backrest	1
WB40-18	Carriage Bolt (M8 x 55mm)	1	WB40-42	Seat	1
WB40-19	Carriage Bolt (M8 x 90mm)	1	WB40-43	Hex Bolt (M10 x 55mm)	2
WB40-20	Hex Bolt (M10 x 60mm)	1	WB40-44	Carriage Bolt (M8 x 85mm)	2
WB40-21	Hex Bolt (M10 x 130mm)	1	WB40-45	Carriage Bolt (M8 x 45mm)	3
WB40-22	Flat Washer (M6)	6	WB40-46	Square End Cap (33.4mm)	5
WB40-23	Flat Washer (M8)	15	WB40-47	Locknut (M6)	2
WB40-24	Spring Washer (M8)	2	WB40-48	Washer (M6)	2
WB40-25	Flat Washer (M10)	8	WB40-49	Tool	2

CLEANING & STORAGE

The device can be cleaned with a soft cloth and mild detergent. Do not use abrasives or solvents on any parts. Please wipe your perspiration off the device. Please keep the device out of direct sunlight. Store the device in a clean, warm and dry environment away from children.

IMPLIED WARRANTY

The importer of this product assures that this device is manufactured with high quality materials. The implied warranty is valid for 1 (one) year, beginning from the date of purchase. The guarantee is valid for home use.

The warranty applies to the following parts:

- Frame
- All parts included in the original delivery

The warranty does not cover:

- Incorrect installation
- Damage caused externally
- Failure to carry out regular maintenance and servicing
- Improper use and handling of the equipment
- Improper storage of the equipment
- Non-compliance of the operating instructions
- Wear parts and expendable parts

MANUFACTURED FOR

Gymstick International Oy
Ratavartijankatu 11
15170 Lahti, FINLAND

DISCLAIMER

The manufacturer and its associates and partners have no liability, obligation or responsibility to any person or entity for any loss, damages or adverse consequence alleges to have happened directly or indirectly as a consequent of this product.



Products marked with these symbols must be disposed of separately from your household waste, as they contain valuable materials which can be recycled. Proper disposal protects the environment and human health. Your local authority or retailer can provide more information on the matter.

