



GYMSTICK™

FTR7 INDOOR RACER USER MANUAL



IMPORTANT: Read all instructions carefully before using this product. Retain this owner's manual for future reference. The specifications of this product may vary from this photo, subject to change without notice.



GYMSTICK.COM

Thank you for choosing the Gymstick FTR7 Indoor Racer. We take great pride in producing this quality product and hope it will provide many hours of effective exercise to make you feel better, look better and enjoy life to its fullest.

TABLE OF CONTENT

1.	SAFETY INSTRUCTIONS	3
2.	EXPLODED DRAWING	4
3.	PARTS LIST	6
4.	ASSEMBLY INSTRUCTION	8
6.	COMPUTER OPERATION INSTRUCTIONS	11
8.	WARM UP AND COOL DOWN ROUTINE	13
9.	IMPLIED WARRANTY	16



NOTIFICATION!

READ AND FOLLOW THE SAFETY INSTRUCTIONS. FAILURE TO FOLLOW THESE INSTRUCTIONS CAN RESULT IN SERIOUS INJURY.

Basic precautions should always be followed, including the following safety instructions when using this equipment: Read all instructions before using this equipment.

1. Keep children and pets away from the machine at all times. DO NOT leave unattended children in the same room with the machine.
2. Handicapped or disabled persons should not use the machine without the presence of a qualified health professional or physician.
3. If the user experiences dizziness, nausea, chest pain, or any other abnormal symptoms, STOP the workout at once. CONSULT A PHYSICIAN IMMEDIATELY.
4. Before beginning training, remove all within a radius of 2 meters from the machine. DO NOT place any sharp objects around the machine.
5. Position the machine on a clear, level surface away from water and moisture. Place mat under the unit to help keep the machine stable and to protect the floor.
6. Use the machine only for its intended use as described in this manual. DO NOT use any other accessories not recommended by the manufacturer.
7. Assemble the machine exactly as the descriptions in the instruction manual.
8. Check all bolts and other connections before using the machine for the first time and ensure that the trainer is in the safe condition.
9. Hold a routine inspection of the equipment. Pay special attention to components which are the most susceptible to wear off, i.e. connecting points and wheels. The defective components should be replaced immediately. The safety level of this equipment can only be maintained by doing so. Please don't use the machine until it is repaired well.
10. NEVER operate the machine if it is not functioning properly.
11. This machine can be used for only one person's training at a time.
12. Do not use abrasive cleaning articles to clean the machine. Remove drops of sweat from the machine immediately after finishing training.
13. Always wear appropriate workout clothing when exercising. Running or aerobic shoes are also required.
14. Before exercising, always do stretching first.
15. The power of the machine increases with increasing the speed, and the reverse. The machine is equipped with adjustable knob, which can adjust the resistance.
16. The maximum weight capacity for this product is **150 kg**.



WARNING!

BEFORE BEGINNING THIS OR ANY EXERCISE PROGRAM, CONSULT YOUR PHYSICIAN FIRST. THIS IS ESPECIALLY IMPORTANT FOR INDIVIDUALS OVER THE AGE OF 35 OR PERSONS WITH PRE-EXISTING HEALTH PROBLEMS.

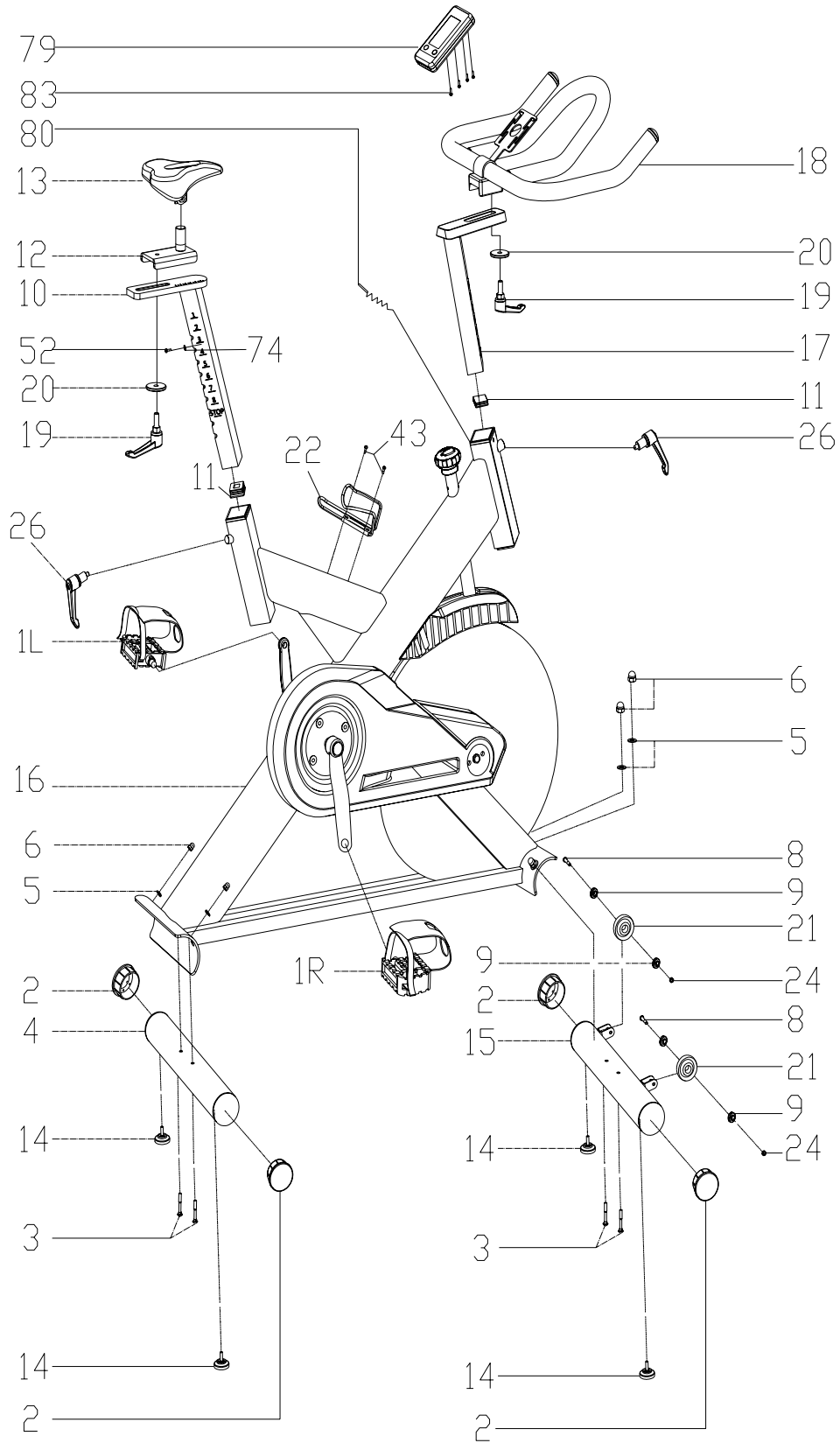

PARTS LIST

NO	NAME	QUANTITY	SPEC
1	PEDAL	1	JD-304 (9/16")
2	END CAP1	4	φ76
3	CARRIAGE BOLT	4	GB/T 12-1988 M10*90
4	REAR STABILIZER	1	WELDING
5	ARC WASHER	4	φ10
6	DOMED NUT	4	GB/T 802-1988 M10
7	WASHER 2	1	M10
8	BOLT	2	GB/T 5780-2000 M8*40
9	BEARING	4	608ZZ
10	VERTICAL SEAT POST	1	WELDING
11	END CAP 2	2	38*38*1.5
12	SEAT POST	1	WELDING
13	SEAT	1	DD-2681
14	STOPPER	4	φ52*39
15	FRONT STABILIZER	1	WELDING
16	MAIN FRAME	1	WELDING
17	HANDLEBAR POST	1	WELDING
18	HANDLE BAR	1	WELDING
19	L SHAPE KNOB	2	M10*25
20	FLAT WASHER 1	3	φ45*φ10.5*4
21	PU WHEEL	2	φ69*23
22	BOTTLE HOLDER	1	φ6
23	DOMED NUT	1	GB/T 802-1988 M10
24	NUT	6	GB/T 889.1-2000 M8
25	BOLT 1	1	GB/T77-2007 M6*6
26	L SHAPE KNOB	2	(M16*1.5)X20mm
27	BOLT 1	4	GB/T 70.2-2000 M8*16
28	FIXING NUT 1	2	M12X1.25 H=8MM
29	CRANK END CAP	2	φ28*6.5
30	KNOB	1	φ60*113
31	NUT	2	GB/T 41-2000 M10
32	Twist The Fixings	1	φ20*34
33	LEFT CRANK	1	170*15
34	CRANK COVER	1	φ56*28
35	BEARING	4	6004ZZ
36	RIGHT CRANK	1	170*15
37	Screw rod	1	Φ13.5*185
38	WASHER 2	3	φ20*φ14*2.0
39	PLASTIC SLEEVE 1	2	38*38*1.5
40	BOLT 10	1	M10*21
41	SCREW 2	8	GB/T 15856.1-2002 ST4.2X19
42	SCREW 3	6	GB/T 15856.1-2002 ST4.2X19
43	SCREW 3	2	GB/845-85 ST4.8X19

PARTS LIST

NO	NAME	QUANTITY	SPEC
44	OUTER CHAIN COVER	1	575*260*45
45	BEARING	2	6203ZZ
46	AXIS	1	φ20*162
47	LONG FIXING TUBE	1	φ25*φ20.2*41.2
48	SHORT FIXING TUBE	1	φ25*φ20.5*12
49	INNER CHAIN COVER	1	287*254*10
50	BELT	1	5P1180
51	BELT WHEEL	1	φ200*24
52	SCREW10	1	GB/845-85 ST4.8X13
53	SPRING 1	1	φ18*62
54	FIXING NUT 3	1	M20*1.0
55	SCREW 3	4	GB/T 5780-2000 M5*10
56	FLYWHEEL COVER	1	294*71*92
57	FLAT WASHER 1	2	GB/T 95-2002 12
58	SHAFT NUT	1	φ18*11
59	BOLT 4	1	GB/T 70.1-2000 M6*40
60	NUT 2	2	GB/T 41-2000 M6
61	FLYWHEEL	1	φ460*15
62	FLYWHEEL SHAFT	1	φ49*90
63	BOLT 5	1	GB/T 70.1-2000 M6*20
64	BOLT 6	4	GB/T 70.1-2000 M6*30
65	FLAT WASHER 1	8	GB/T 95-2002 6
66	FIXING NUT	1	M20*1.0
67	FLYWHEEL HOLDER	2	129*56.5*15
68	BOLT 7	4	GB/T 70.1-2000 M6*12
69	BOLT 8	1	GB/T 70.1-2000 M6*12
70	ADJUSTING METAL	1	117*14.5*51.5
71	BLOCK	1	161*21*19
72	WOOLLY BLOCK	1	153*16*4
73	BOLT 9	2	GB/T 5780-2000 M5*10
74	SPRING WASHER 1	3	GB/T 859-1987 5
75	SPRING WASHER 2	8	GB/T 859-1987 6
76	LITTLE BELT WHEEL	1	φ64*23
77	FIXING NUT	2	27*6(M20*1)
78	SHAFT	1	φ25*45
79	COMPUTER	1	TE-2000-3
80	SENSOR	1	SR-202
81	BLUETOOTH LANCHER	1	L=150
82	Plastic plug	2	φ14*14
83	SCREW 4	4	GB/T 5780-2000 M5*8
84	EVA paddle	1	95*16*9
85	EVA paddle	1	50*20*4
86	BOLT 10	2	GB/845-85 M6*16

PREPARATION

- A. Before assembling make sure that you will have enough space around the item.
- B. Use the present tooling for assembling.
- C. Before assembling please check whether all needed parts are available (at the above of this instruction sheet you will find an explosion drawing with all single parts (marked with numbers) which this item consists of.

STEP 1

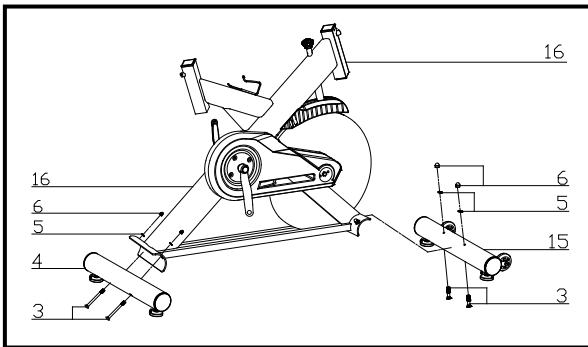

Attach the Front Stabilizer (pt.15) to the Main Frame (pt.16) using two sets of Ø10 Arc Washers (pt.5), M10 Domed Nut (pt.6) and M8*90 Carriage bolt (3).

Attach the Rear Stabilizer (pt.4) to the Main Frame (pt.16) using two sets of Ø10 Arc Washers (pt.5), M10 Domed Nut (pt.6) and M8*90 Carriage bolt (3).

STEP 2

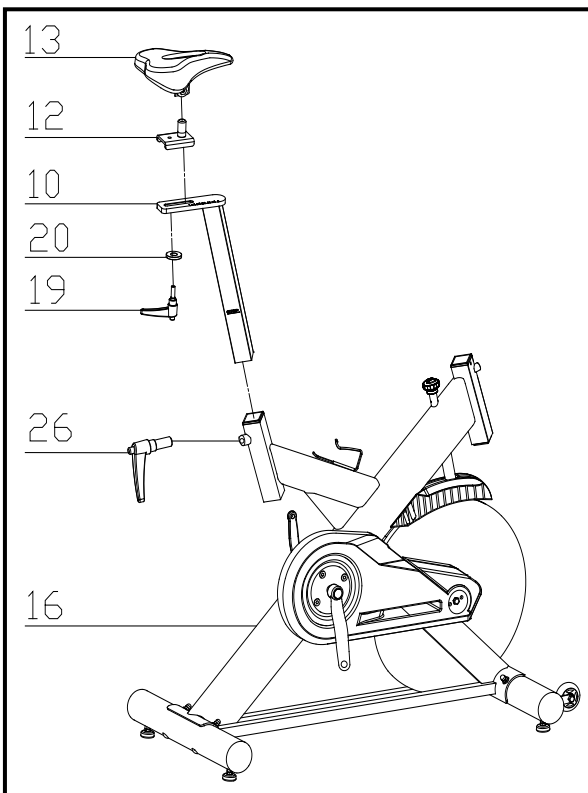

Slide the Vertical Seat Post (pt.10) into the seat post housing on the main frame (pt.16).

Then slide the Seat Post (pt.12) into the Vertical Seat Post (pt.10), then Secure using a flat washer 1 (20) and L Shape knob (19). You will have to slacken the knurled section of the L Shape Knob (pt.19) and pull the knob back and then select the desired height. Release the knob and retighten the knurled portion.

Now fix the Seat (pt.13) to the Seat Post (pt.12) as shown, and tighten the bolts around the screws under the seat.

STEP 3

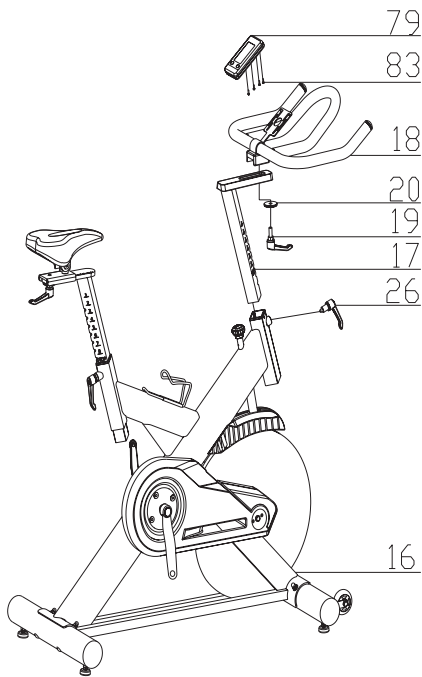

Slide the Handlebar Post (pt.17) into the handlebar post housing on the main frame (pt.16). You will have to slacken the knurled section of the L Shape Knob (pt.26) and pull the knob back and then select the desired height. Release the knob and retighten the knurled portion.

Then fix the Handlebar (pt.18) with a flat washer 1 (20) and L Shape knob (19)

ATTENTION: YOU SHOULD FIX THE HANDLEBAR TIGHTLY.

Fix the Computer (pt.79) onto the Computer Holder with bolt (pt.83).

WIRELESS TRANSMITTER

The wireless transmitter is located nearby the crank.

Make sure the power switch on the wireless transmitter is in ON position.

When needed replace the battery according to the drawing. Battery specifications: CR2032

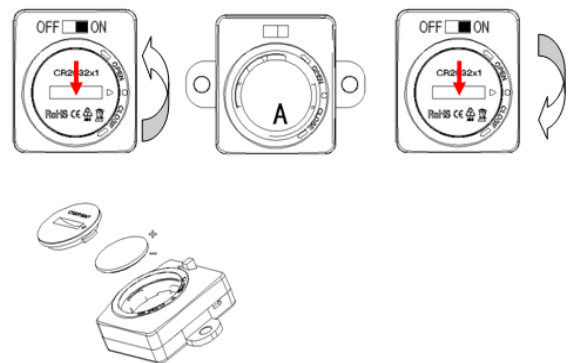

STEP 4

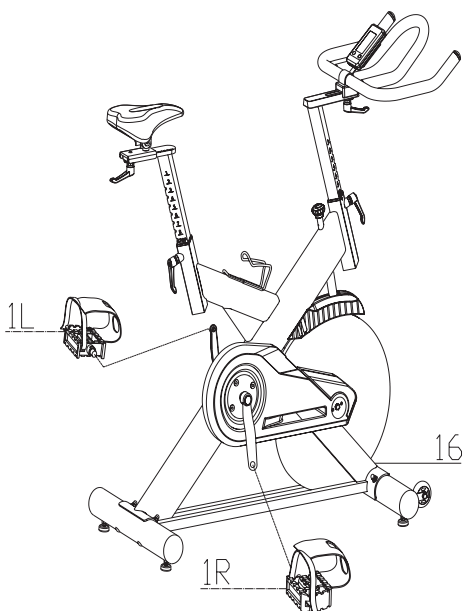

The Pedals (pt.1 L & pt.1 R) are marked "L" and "R" - Left and Right.

Connect them to their appropriate crank arms. The right crank arm is on the right- hand side of the cycle as you sit on it.

NOTE: The Right pedal should be threaded on clockwise and the Left pedal anticlockwise.

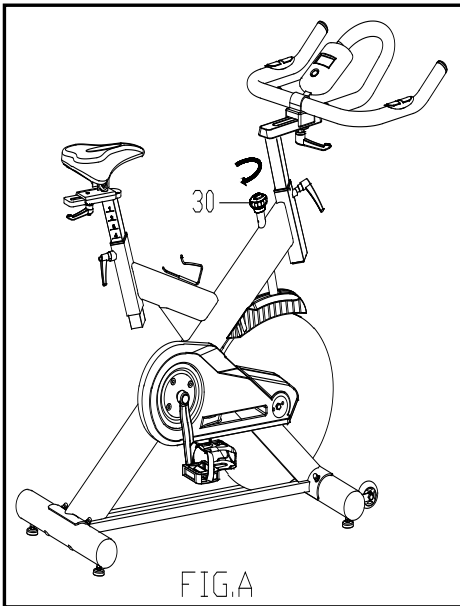

Increasing or decreasing the tension allows you to add variety to your workout sessions by adjusting the resistance level of the bike.

INCREASE TENSION

To increase tension and increase resistance (requiring more strength to pedal), turn the Emergency Brake & Tension Control Knob (#30) to the right.

DECREASE TENSION

To decrease tension and increase resistance (requiring less strength to pedala), turn the Emergency Brake & Tension Control Knob (#30) to the left B.

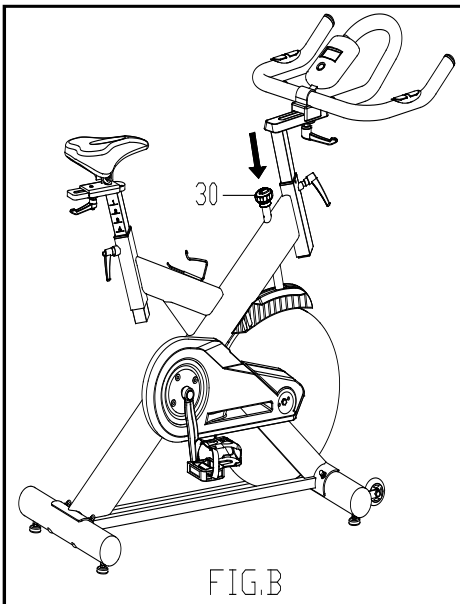

EMERGENCY BRAKE FUNCTION

The same knob that allows you to adjust the tension of the bike also doubles as the Emergency Brake.

Use this safety feature in any situation where you would need to get off the bike and/or stop the bike's flywheel.

To use the Emergency Brake function in any situation you would need it in, firmly press down on the Emergency Brake & Tension Control Knob (#30).

SEAT AND HANDLEBAR ADJUSTMENT

SEAT

To adjust the seat height, slacken the spring knob on the vertical post stem on the main frame and pull back the knob. Position the vertical seat post for the desired height so that holes are aligned, then release the knob and retighten it.

To move the seat forward in the direction of the handlebar or backwards away from it, loosen the adjusting knob and washer and pull the knob back. Slide horizontal seat post into desired position. Align holes and then retighten the adjusting knob.

HANDLEBAR

To adjust the handlebar height, slacken the spring knob and secondary knob and pull both knobs back. Slide the handlebar post along the housing on the main frame to the desired height and, with the holes aligned correctly, tighten the spring adjusting knob and then the secondary knob.



BUTTONS

- MODE/RESET** To confirm all settings. Press this button and hold for 2 seconds to reset all function figures.
- SET** To set up the value of TIME, DISTANCE, CALORIES. You can hold the button to increase the value fast (the computer has to be in stop condition.)

FUNCTIONS

- SCAN:** Displays all function TIME→DISTANCE→CALORIES→ RPM/SPEED in sequence.
- RPM:** Displays the pedaling Rotation Per Minute. The RPM and SPEED will switch to another display in every 6 seconds after exercise starts.
- SPEED:** Displays the user's exercise speed.
- TIME:** 1.You can press "SET" button to set target time between 0:00 to 99:00 for count down function.
2. It can be set up by the user or accumulated automatically for count up function.
- DISTANCE:** 1.You can press "SET" button to set target distance between 0:00 to 99:50 for count down function.
2. It can be set up by the user or accumulated automatically for count up function.
- CALORIES:** 1.You can press "SET" button to set target calories between 0 to 9990 for count down function.
2. It can be set up by the user or accumulated automatically for count up function.

OPERATION

INSTALL BATTERY

When installing the battery, the screen will display as following (drawing on left) and have "Bi" sound at the same time.

After that, it goes to the next step to the main menu as (drawing on right)

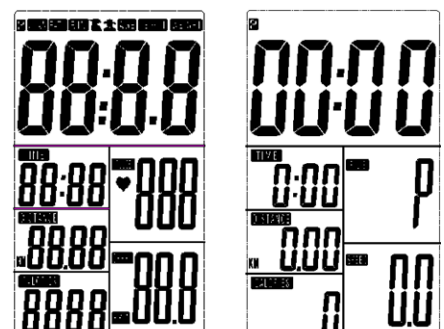

OPERATION PROCEDURE

When you are in each set-up mode, for example in the time set-up mode, time value is blinking, you can press "SET" button to adjust the value and press "MODE" for confirmation.

With any signal been transmitted into the monitor, the value of TIME, DISTANCE, CALORIES start to count up. When there is any function has been preset the target (TIME or DISTANCE or CALORIES), the function will be counting down from the preset to zero while the training starts. Once the target is achieved to zero, the monitor start to beep for 8 seconds, and the function will be counting up from zero directly if the training is going on. Press "MODE" button for confirmation and skip to next set-up.

You can also press "MODE" button to select single function display, except RPM & SPEED function. The RPM & SPEED function will switch display.

NOTE

1. Stop training for 4 minutes, the computer will enter sleep mode. Press any button to have the computer restart working, the original value will retain. (if re-install batteries, the original value will be erased)
2. If the computer displays abnormally, please re-install battery and try again.

HOW TO REPLACE THE BATTERY

1. Hold up the clip on the battery cover and remove the battery cover.
2. Remove the old battery and install a new CR2032 (3V) battery by tilting the battery slightly to its side and slide it in.

Note: positive (+) at upper side and negative (-) at down side.

3. For the battery change, please gently press the clip on the side and the battery will pup up.
4. Place the battery cover back.

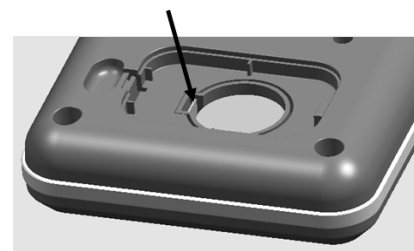
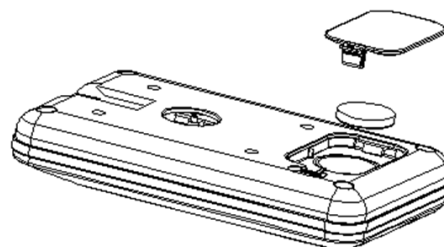

HEART RATE SENSOR

This product is compatible with standard 5.3Khz wearable heart rate detector. During a workout, the heart rate features appear on the display when you wear a chest strap. After you put on the chest strap, face the display console for a minimum of 15 seconds. This allows the receiver in the console to recognize the signal from the chest strap.

- A. Carefully dampen the back of the strap with tap water.
- B. Adjust the strap and fasten it around your chest. The strap should feel snug, not restrictive.
- C. Make sure that the chest strap is right side up, lies horizontally across your chest, and is centered in the middle of your chest.

Note! If the heart rate is not displayed, make sure that the heart rate transmitter is switched on and that the batteries are OK.



Diagram A



Diagram B



Diagram C

A good exercise program consists of a warm-up, aerobic exercise, and a cool down. Do the entire program at least two to three times a week, resting for a day between workouts. After several months you can increase your workouts to four or five times per week.

AEROBIC EXERCISE is any sustained activity that sends oxygen to your muscles via your heart and lungs. Aerobic exercise improves the fitness of your lungs and heart. Aerobic fitness is promoted by any activity that uses your large muscles eg: legs, arms and buttocks. Your heart beats quickly and you breathe deeply. An aerobic exercise should be part of your entire exercise routine.

The **WARM-UP** is an important part of any workout. It should begin every session to prepare your body for more strenuous exercise by heating up and stretching your muscles, increasing your circulation and pulse rate, and delivering more oxygen to your muscles.

COOL DOWN at the end of your workout, repeat these exercises to reduce soreness in tired muscles.



HEAD ROLLS

Rotate your head to the right for one count, feeling the stretch up the left side of your neck, then rotate your head back for one count, stretching your chin to the ceiling and letting your mouth open. Rotate your head to the left for one count, then drop your head to your chest for one count.



SHOULDER LIFTS

Lift your right shoulder toward your ear for one count. Then lift your left shoulder up for one count as you lower your right shoulder.



SIDE STRETCHES

Open your arms to the side and lift them until they are over your head. Reach your right arm as far toward the ceiling as you can for one count. Repeat this action with your left arm.



QUADRICEPS STRETCH

With one hand against a wall for balance, reach behind you and pull your right foot up. Bring your heel as close to your buttocks as possible. Hold for 15 counts and repeat with left foot.



INNER THIGH STRETCH

Sit with the soles of your feet together and your knees pointing outward. Pull your feet as close to your groin as possible. Gently push your knees toward the floor. Hold for 15 counts.

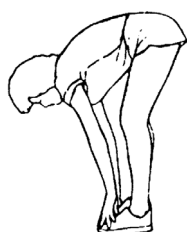

TOE TOUCHES

Slowly bend forward from your waist, letting your back and shoulders relax as you stretch toward your toes. Reach as far as you can and hold for 15 counts.



HAMSTRING STRETCHES

Extend your right leg. Rest the sole of your left foot against your right inner thigh. Stretch toward your toe as far as possible. Hold for 15 counts. Relax and then repeat with left leg.



CALF/ACHILLES STRETCH

Lean against a wall with your left leg in front of the right and your arms forward. Keep your right leg straight and the left foot on the floor; then bend the left leg and lean forward by moving your hips toward the wall. Hold, then repeat on the other side for 15 counts.

The importer of this product assures that this device is manufactured with high quality materials.

The prerequisite for the implied warranty is the proper setup in accordance with the operating instructions. Improper use and /or incorrect transportation can void the warranty.

The implied warranty for wear parts is valid for 1 year and for frame 3 years, beginning from the date of purchase. For eventual defects please contact the dealer of this product within the guarantee period.

The warranty applies to the following parts (as far as included in the scope of delivery): frame, electronic devices, wheels, foot straps and pedals.

The guarantee does not cover:

- Damage effected by outer force
- Intervention by unauthorized parties
- Incorrect handling of the product
- Non-compliance of the operating instructions

Note: Wear parts and expendable parts are also not covered.

The device is intended for home use.

Manufactured for:
Gymstick International Oy
Ratavartijankatu 11
15170 Lahti, FINLAND

DISCLAIMER:

The manufacturer and its associates and partners have no liability, obligation or responsibility to any persons or entity for any loss, damages or adverse consequence alleges to have happened directly or indirectly as a consequent of this product.

For your own safety be sure that you read all the instructions in this manual before using this product!



Devices marked with this symbol must be disposed of separately from your household waste, as they contain valuable materials which can be recycled. Proper disposal protects the environment and human health. Your local authority or retailer can provide information on the matter.

