

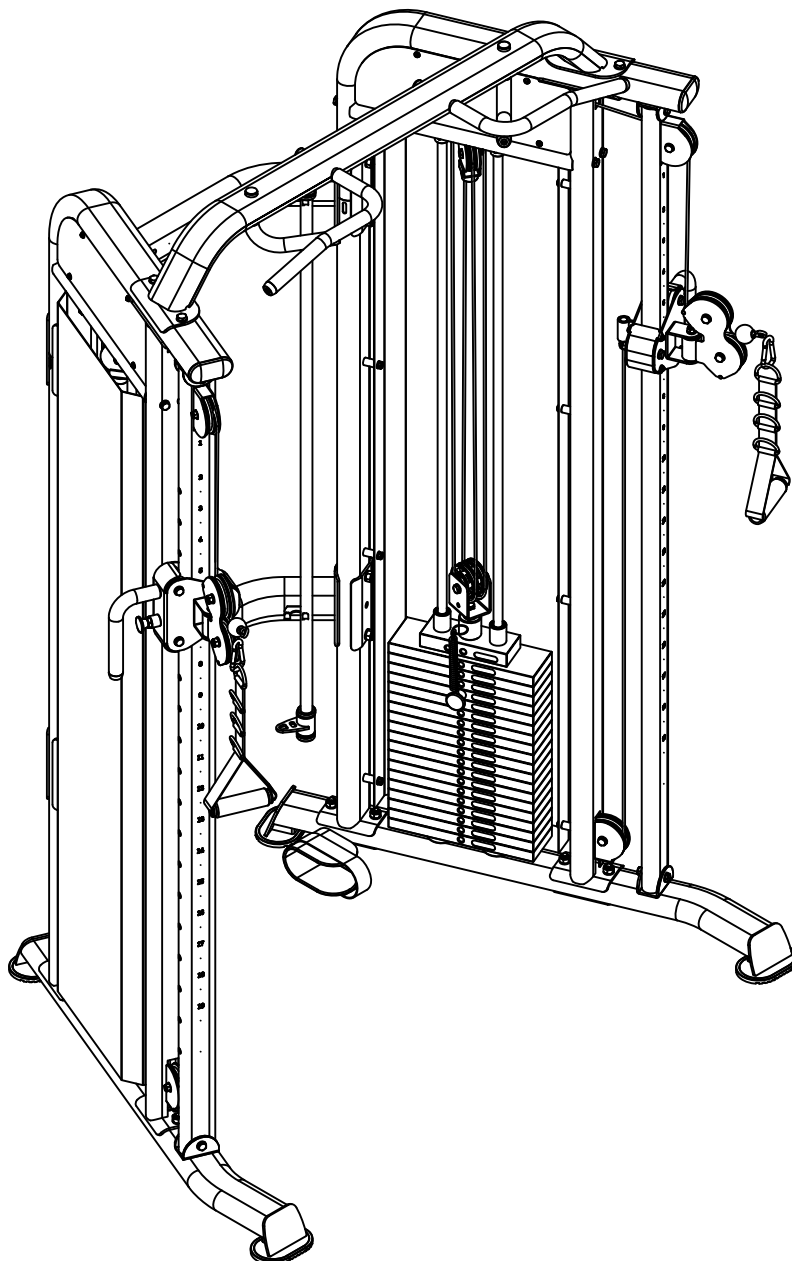

MANUAL FUNCTIONAL TRAINER X20



Master marknadsförs av Vartex AB, Batterivägen 14, 43234 Varberg, Sweden

www.masterfitness.se

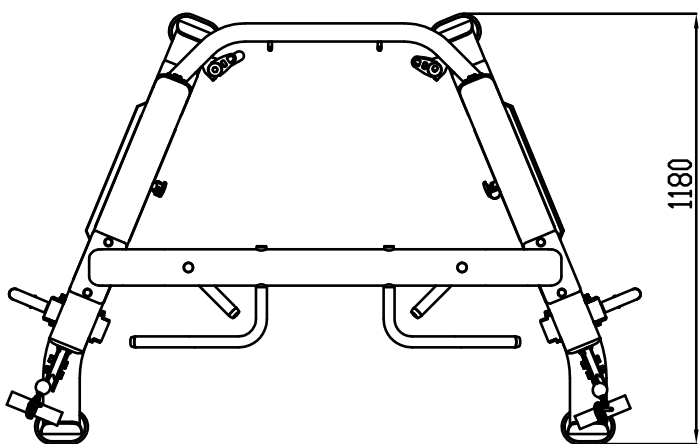
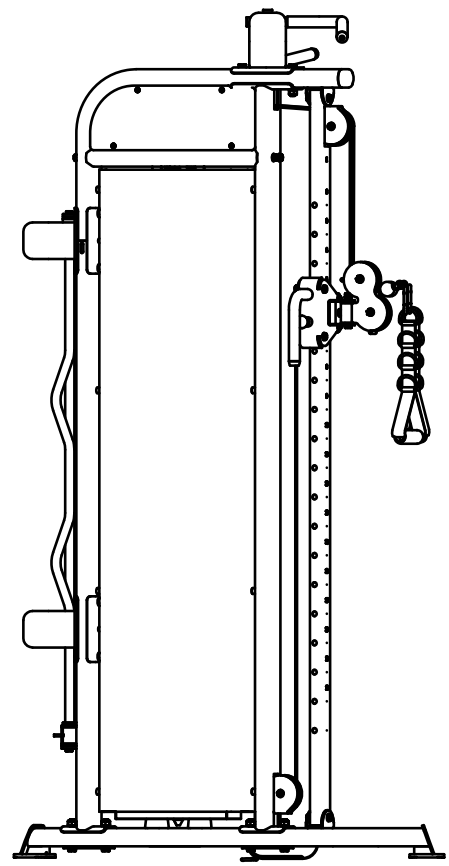
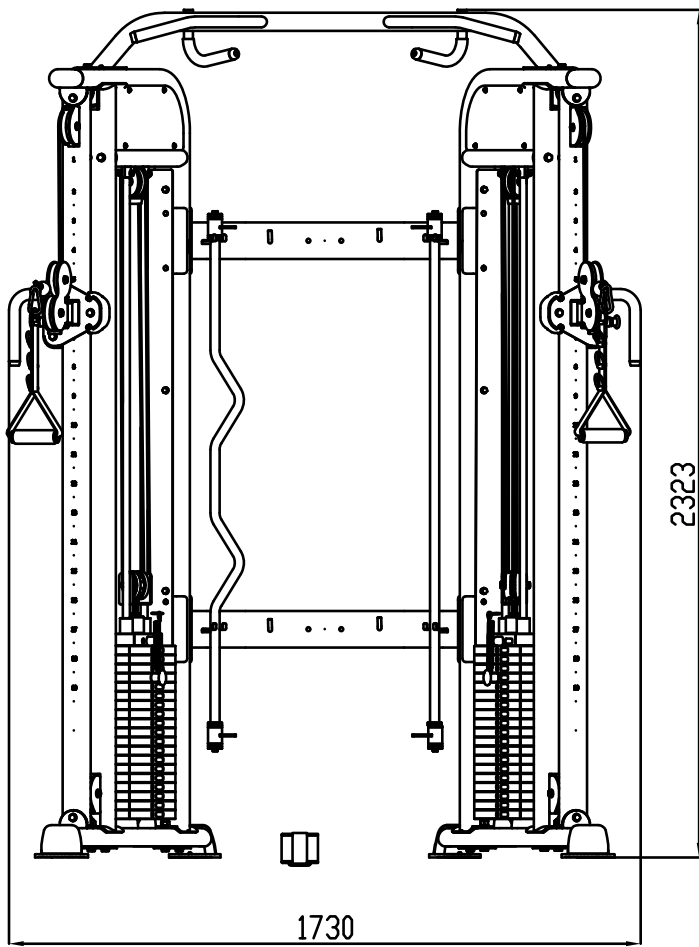

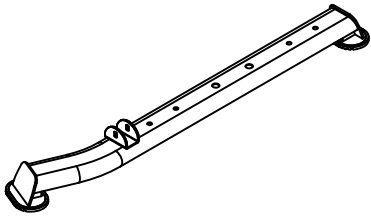

① × 1

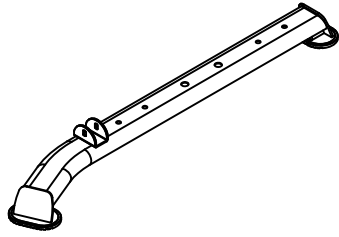

② × 1

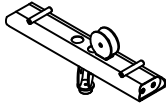

⑤ × 1

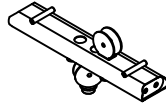

⑥ × 1

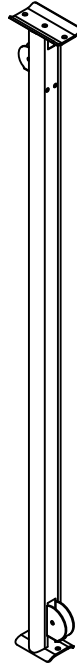

③ × 2

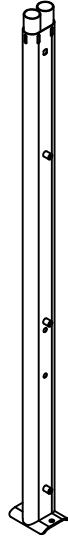

④ × 2

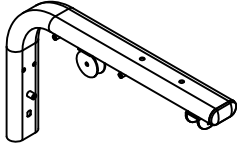

⑦ × 2

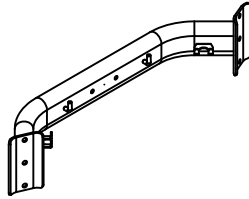

⑧ × 2

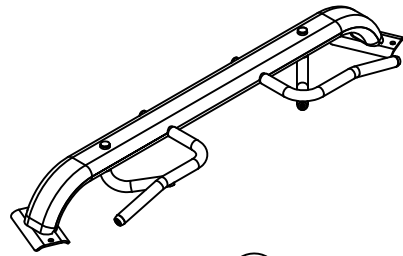

⑨ × 1



⑩ × 1



⑪ × 1



⑫ × 2

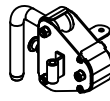

⑬ × 1



⑭ × 1



⑮ × 2

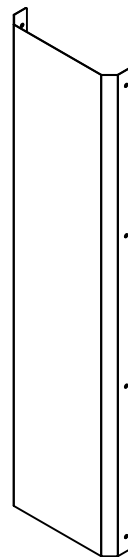

⑯ × 2

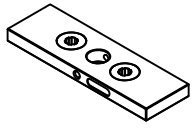

17 x 38

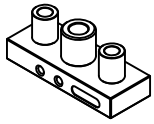

18 x 2



19 x 4

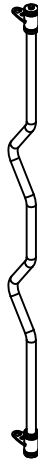

24 x 1

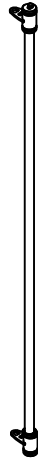

25 x 1

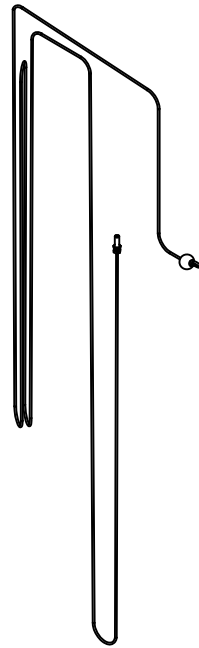

28 x 2

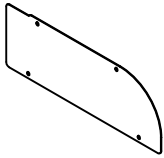

22 x 4



26 x 4



33 x 4

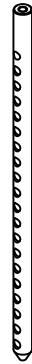

35 x 2



36 x 8



37 x 12

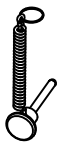

38 x 2



46 x 2



47 x 1



68 x 2

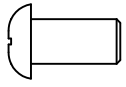

⑤0 × 16

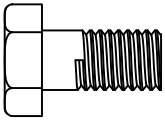

⑤1 × 16



⑤3 × 4

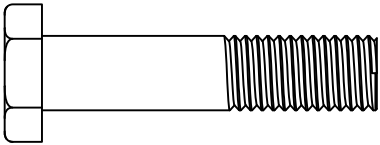

⑤4 × 16

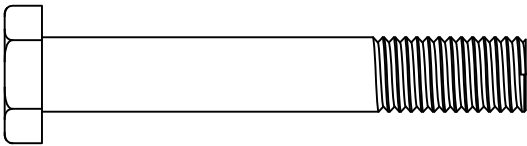

⑤5 × 4

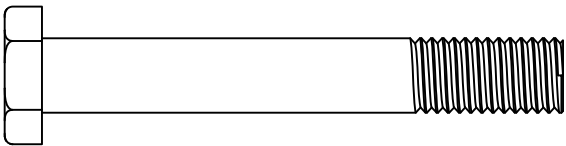

⑤6 × 8

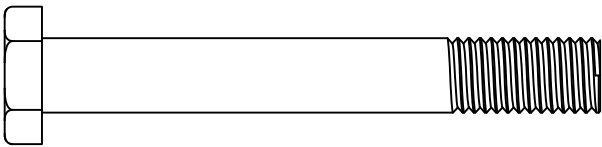

⑤7 × 2

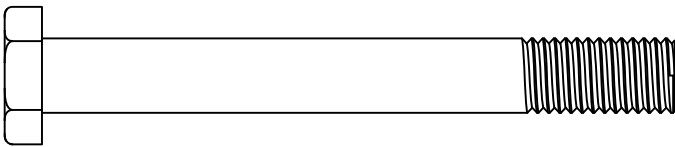

⑤8 × 2

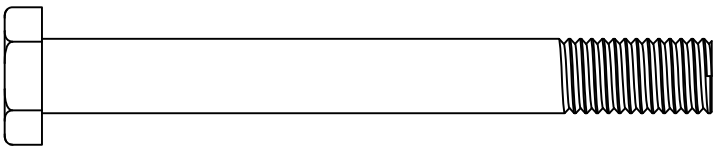

⑤9 × 2

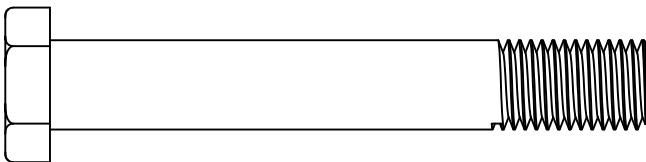

⑥0 × 20

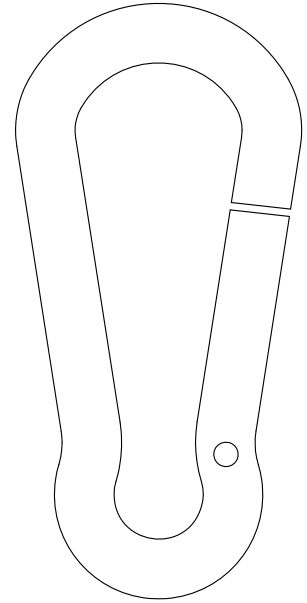

④0 × 2

mm

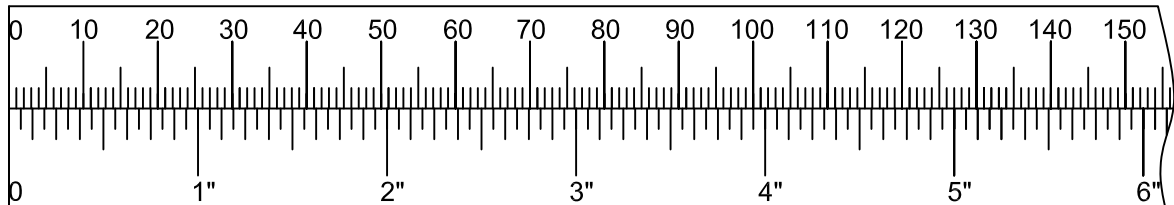



61 × 16



64 × 16



62 × 16

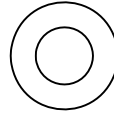

65 × 16



63 × 8

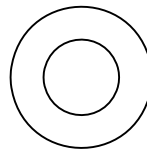

66 × 56

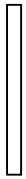
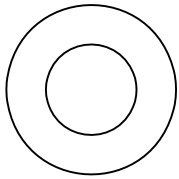

67 × 40

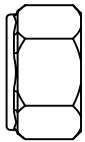

69 × 26

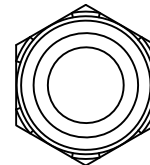
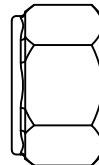

70 × 20



4# × 1

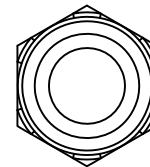

71 × 2

mm

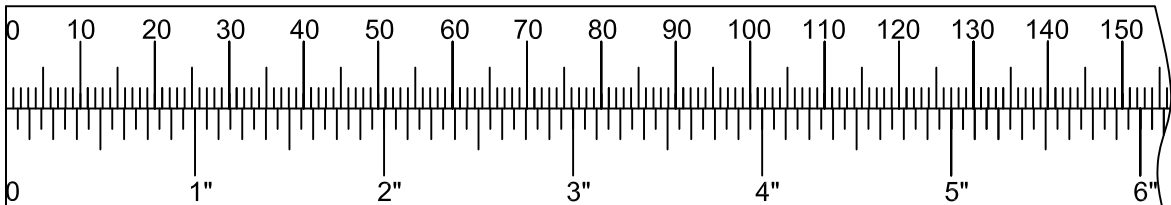

60

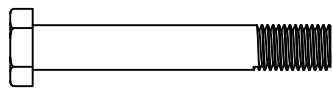

×4

M12×80

67



×8

Φ12

70



×4

M12

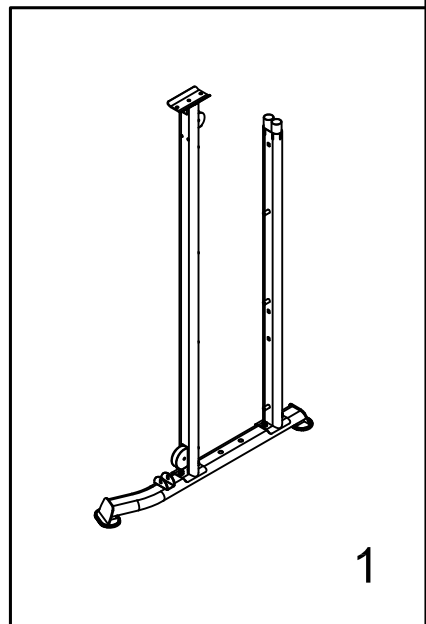
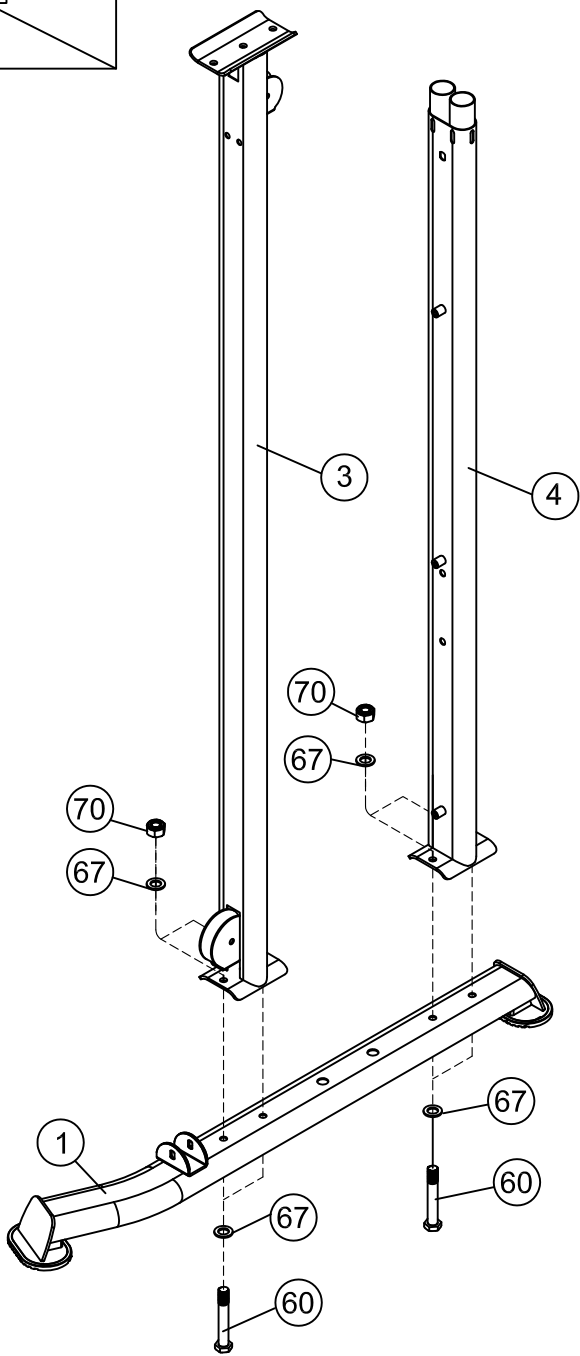
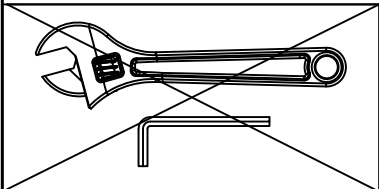

1

(60)  ×4 M12×80 (67)   ×8 Φ12

(70)   ×4 M12

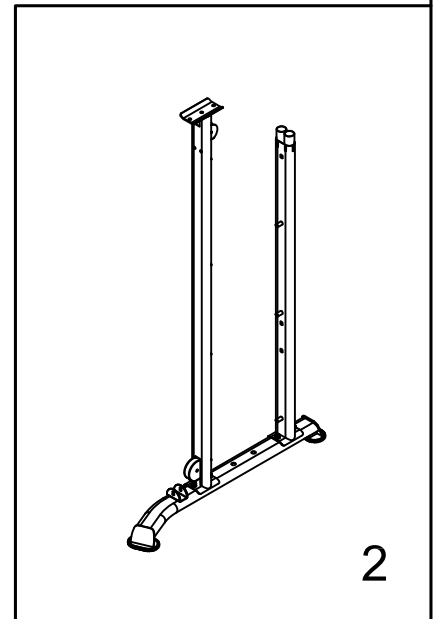
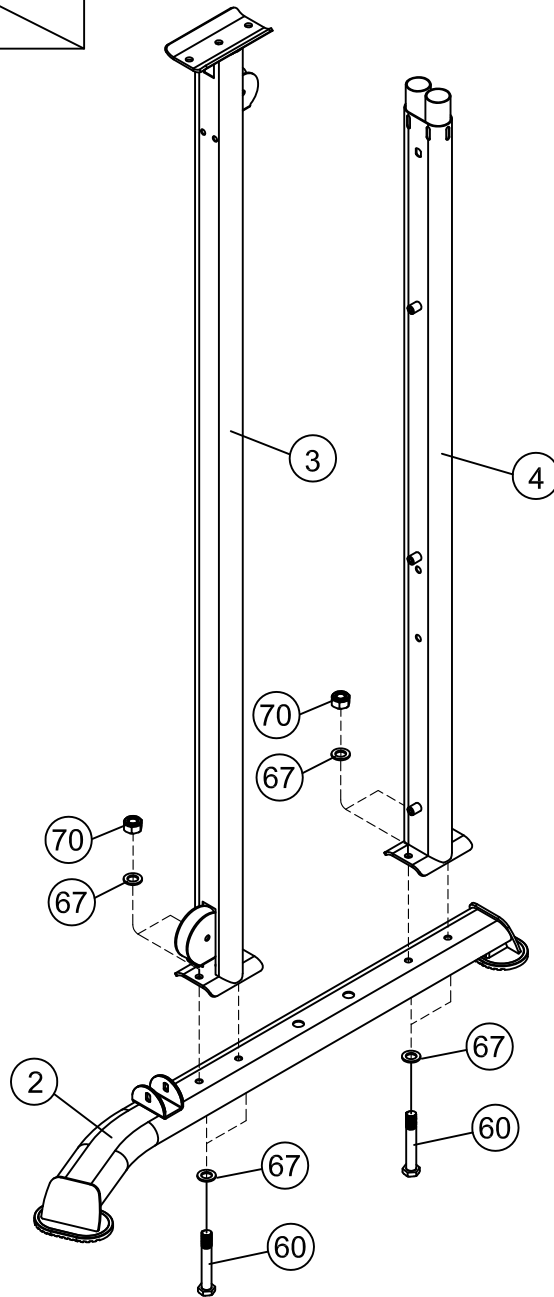
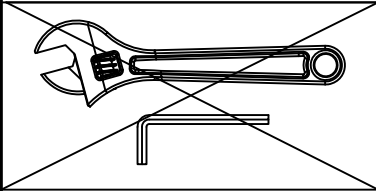

60

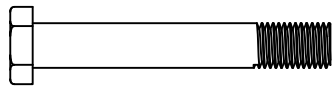

×4

M12×80

67



×8

Φ12

70



×4

M12

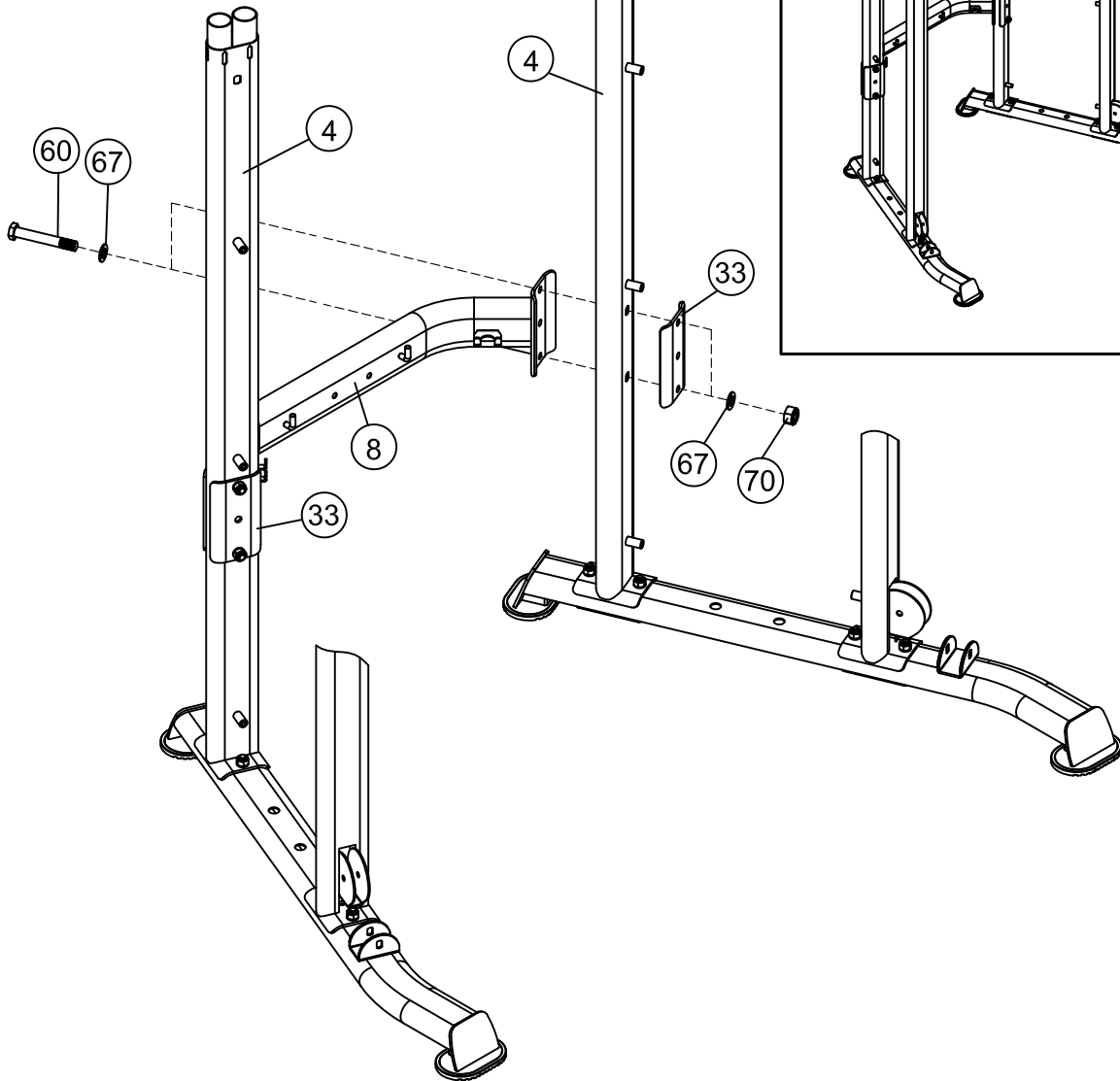
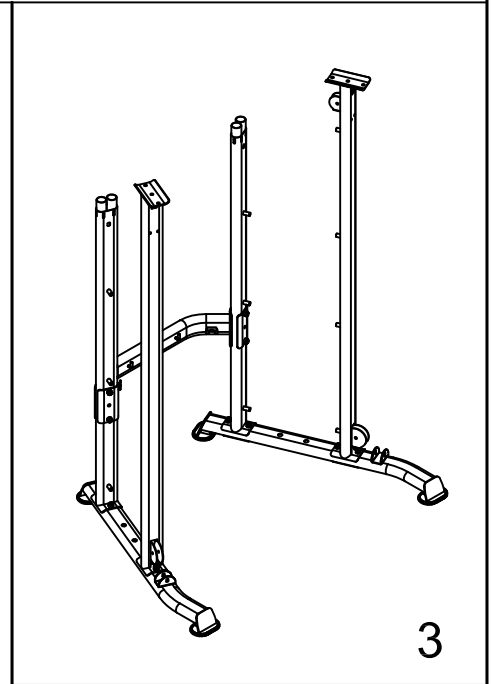
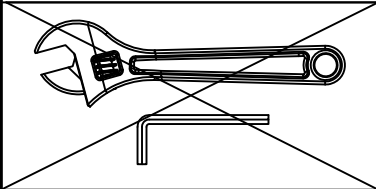

59

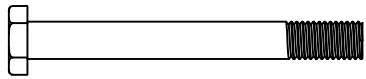

×2

M10×90

69



×2

M10

71

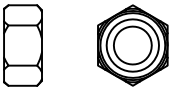

×2

M12

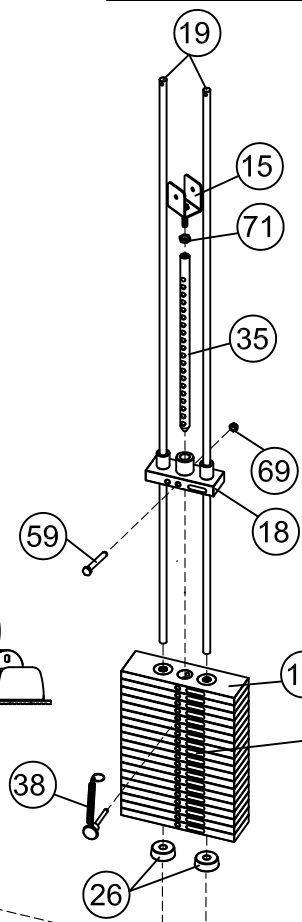
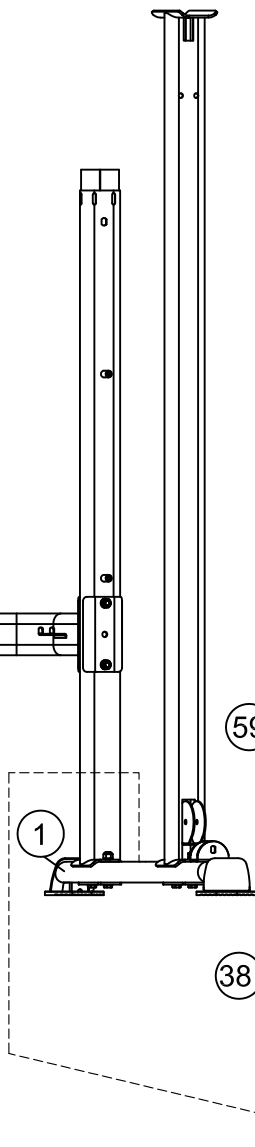
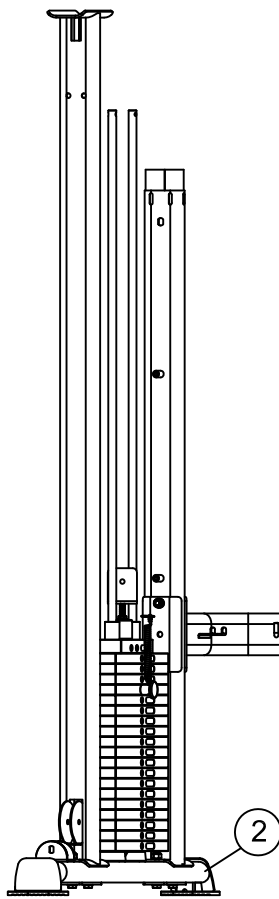
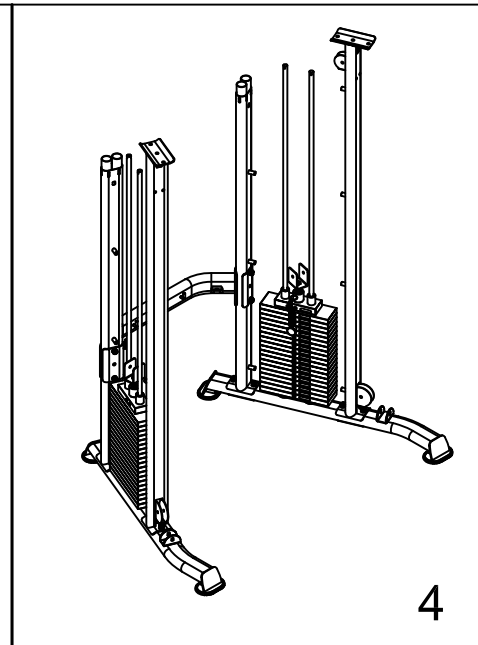
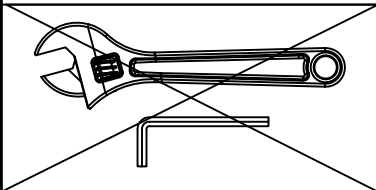

68

- 6KG/13LB
- 12KG/26LB
- 18KG/39LB
- 24KG/52LB
- 30KG/65LB
- 36KG/78LB
- 42KG/91LB
- 48KG/104LB
- 54KG/120LB
- 60KG/133LB
- 66KG/146LB
- 72KG/159LB
- 78KG/172LB
- 84KG/185LB
- 90KG/198LB
- 96KG/ 211LB
- 102KG/224LB
- 108KG/238LB
- 114KG/251LB
- 120KG/264LB

53



×2 M8×10

56

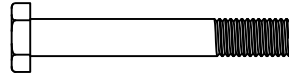

×4

M10×70

63



×4 Φ10

66



×4 Φ10

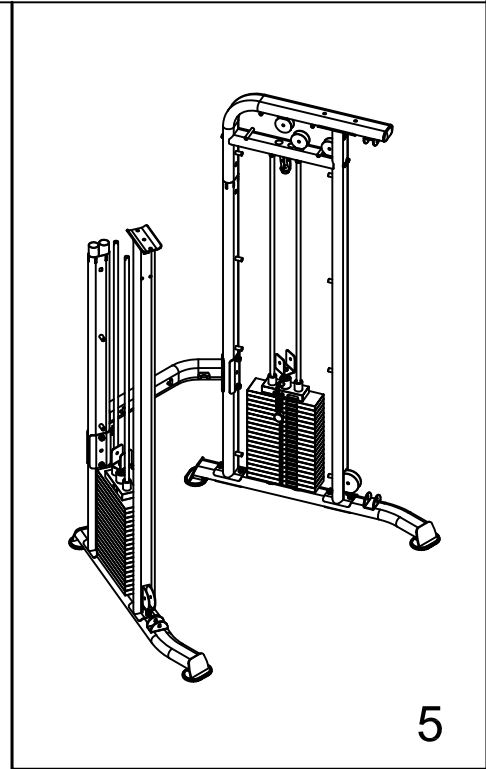
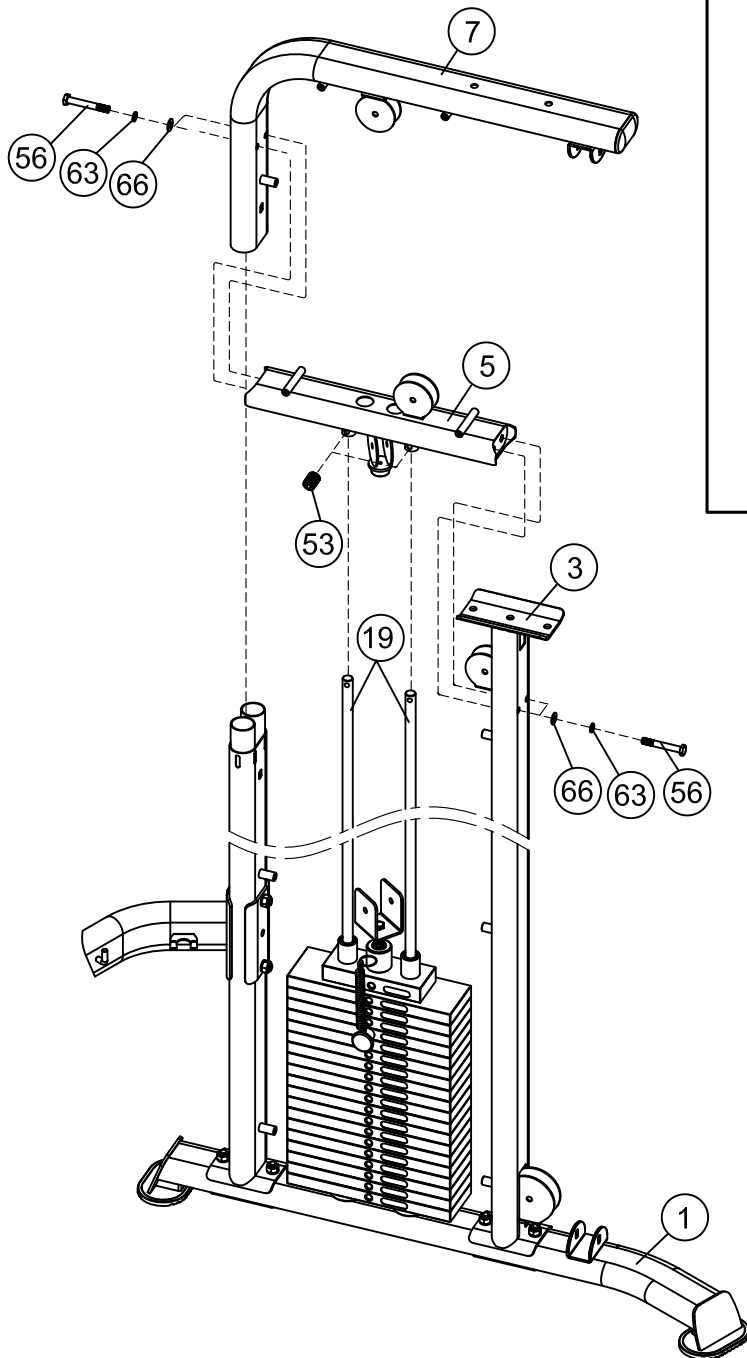
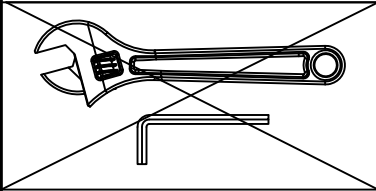

53



×2 M8×10

56

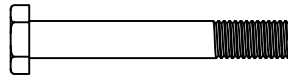

×4

M10×70

63



×4 Φ10

66



×4 Φ10

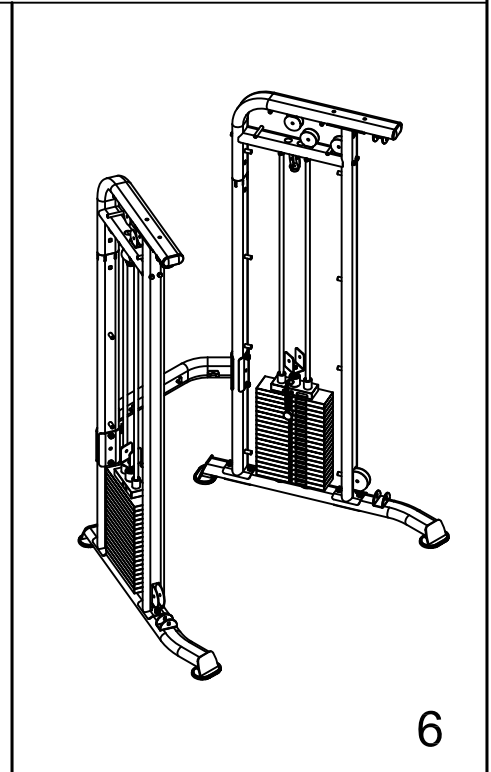
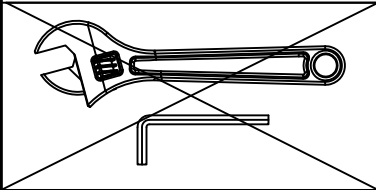

6

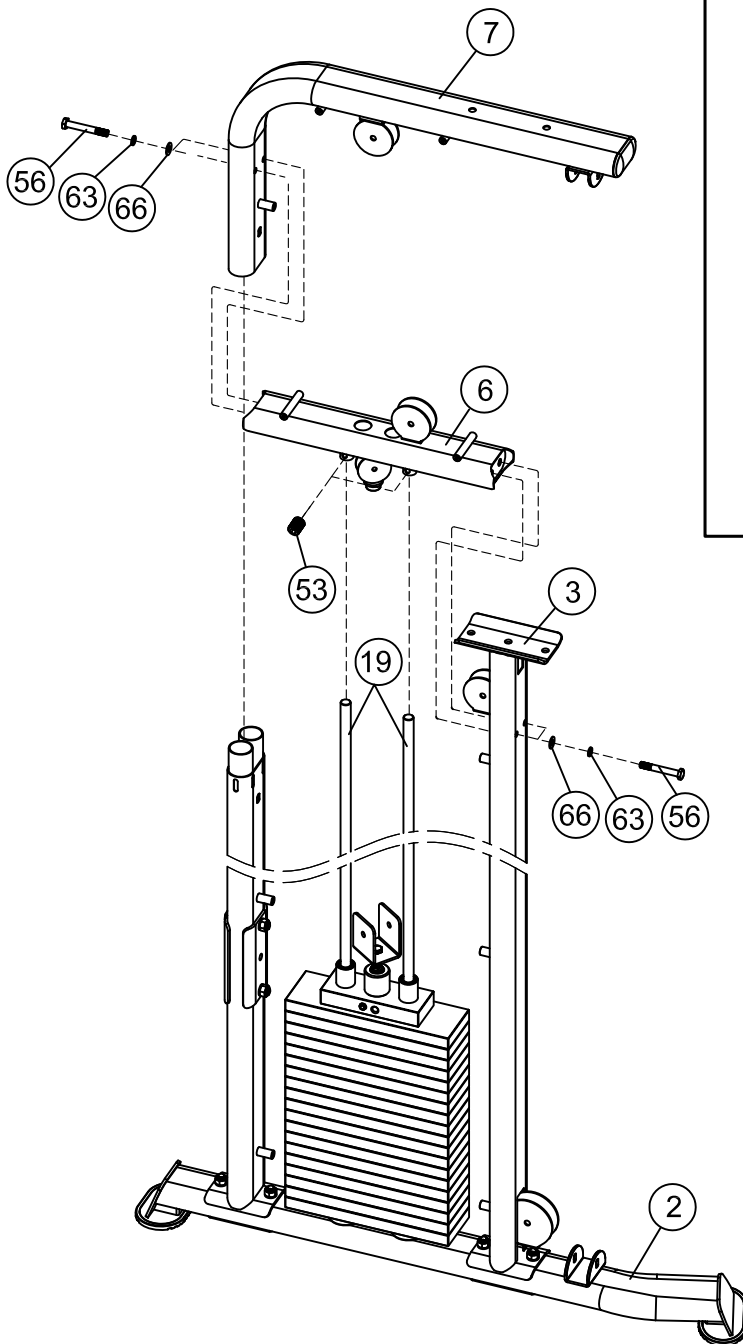

60

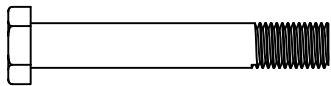

×4

M12×80

67



×8

Φ12

70



×4

M12

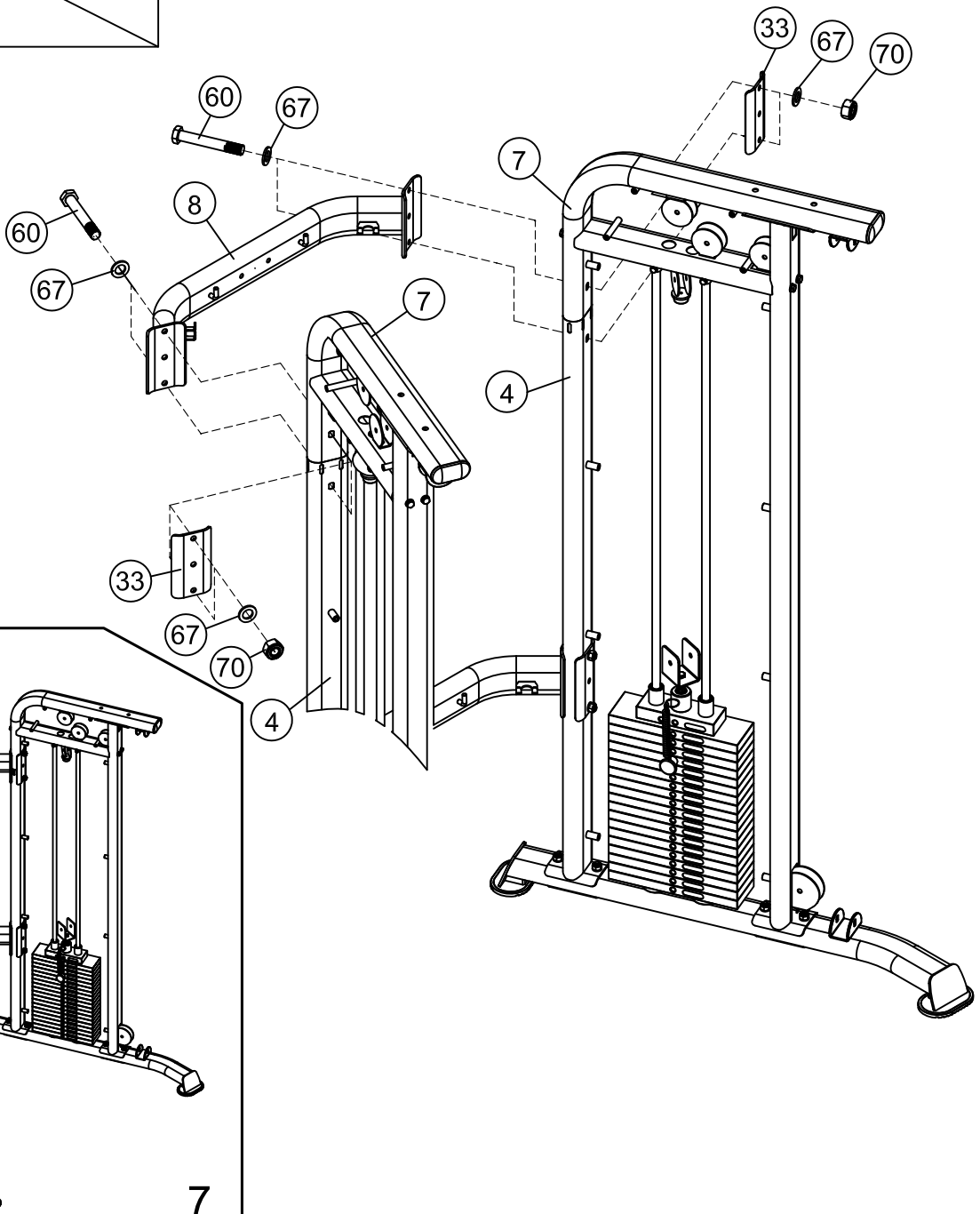
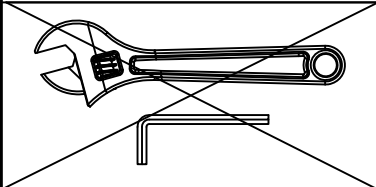

60

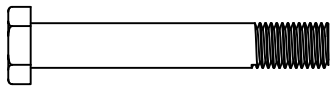

×4

M12×80

67



×8

Φ12



70



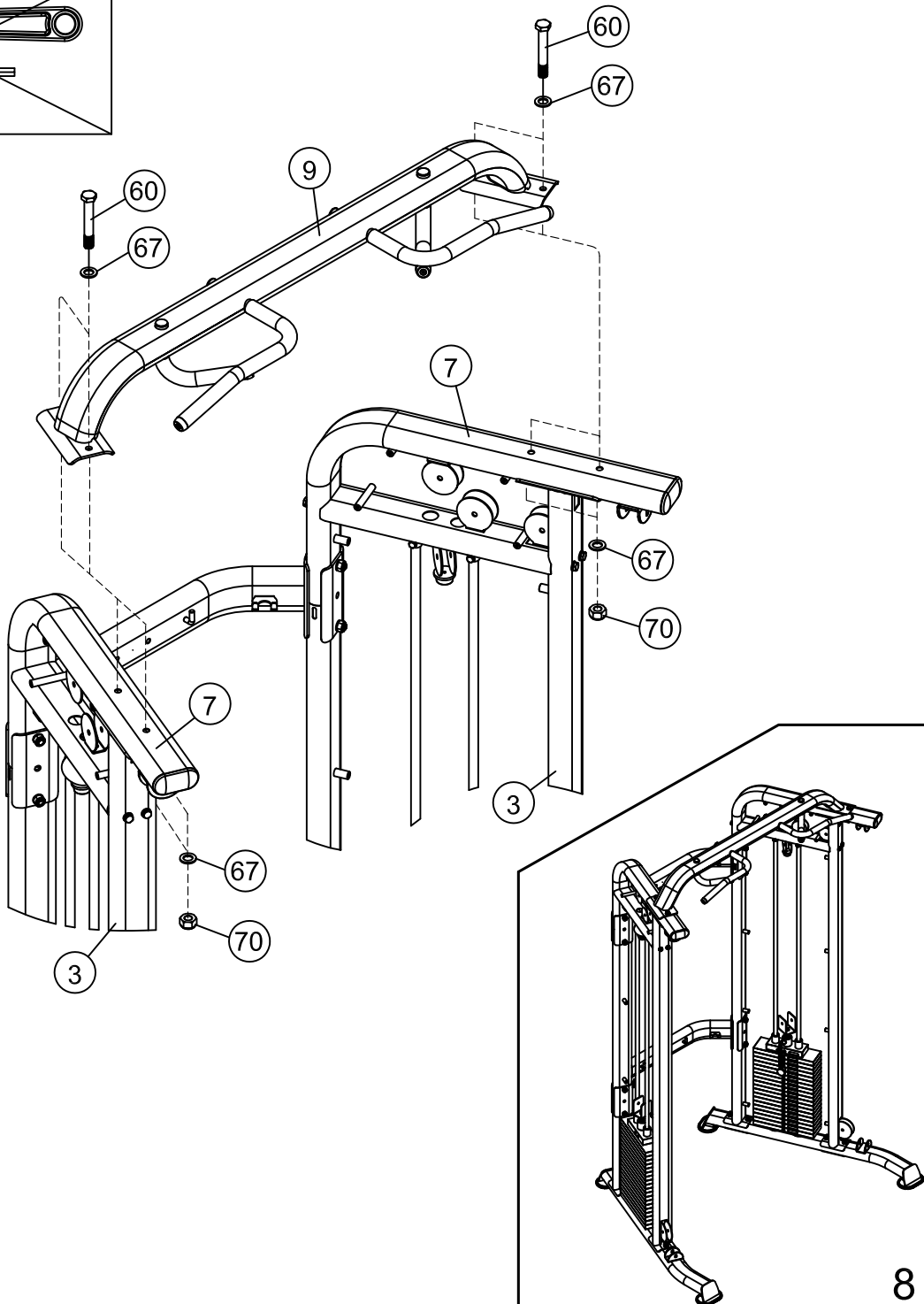
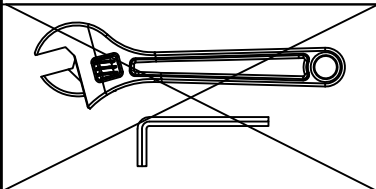

×4

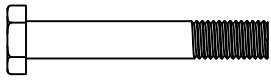
M12



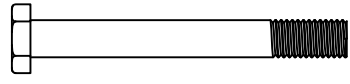

55  ×2 M10×65
 66   ×6 Φ10

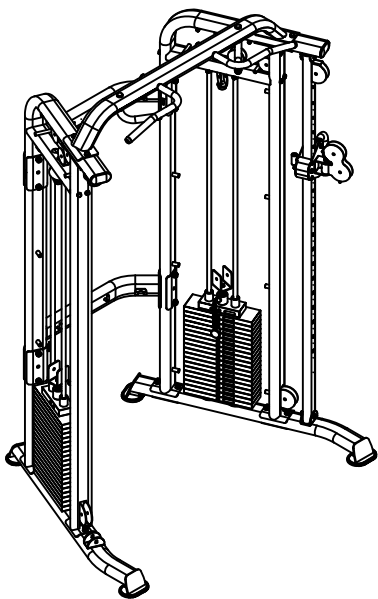
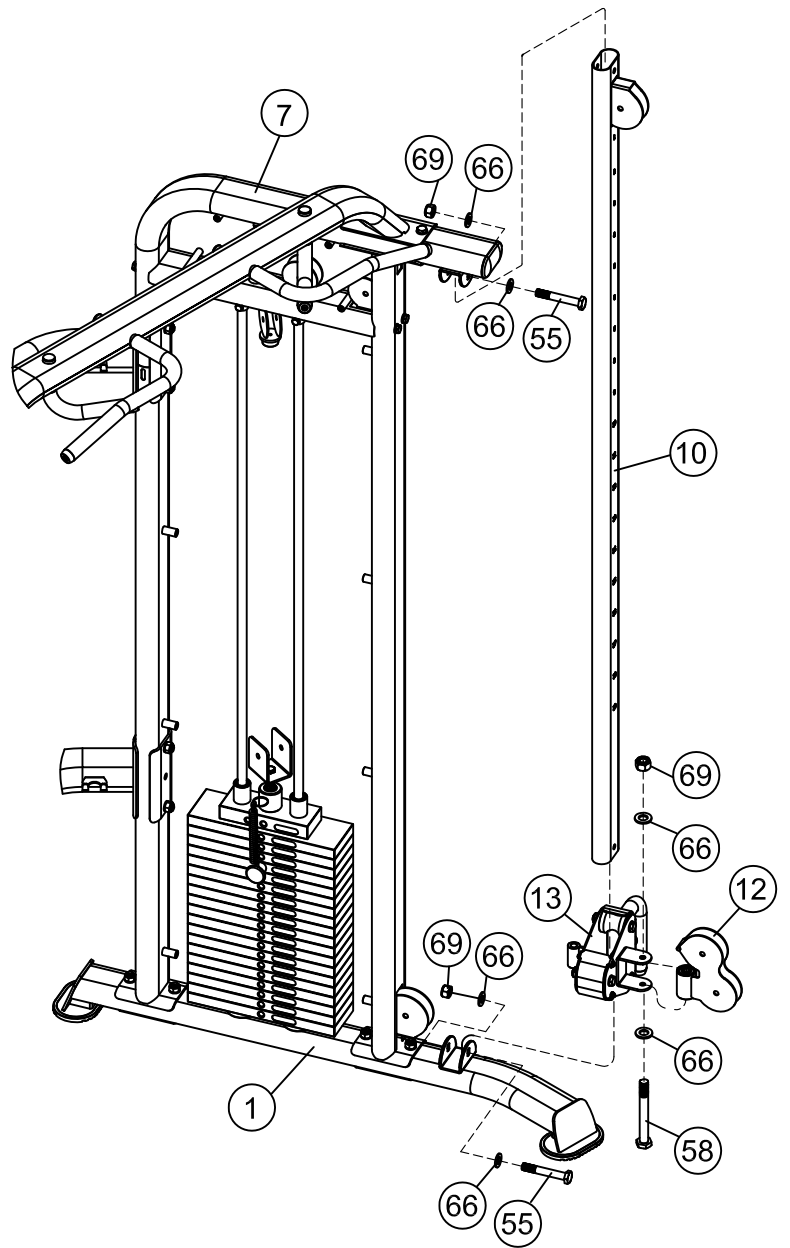
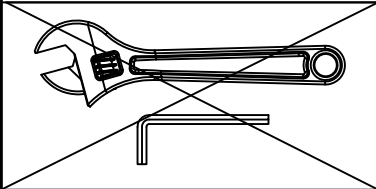
58  ×1 M10×85
 69   ×3 M10

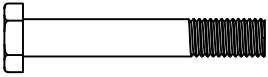

9

55  ×2 M10×65

66   ×6 Φ10

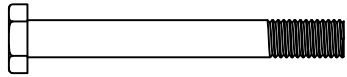
58  ×1 M10×85

69   ×3 M10

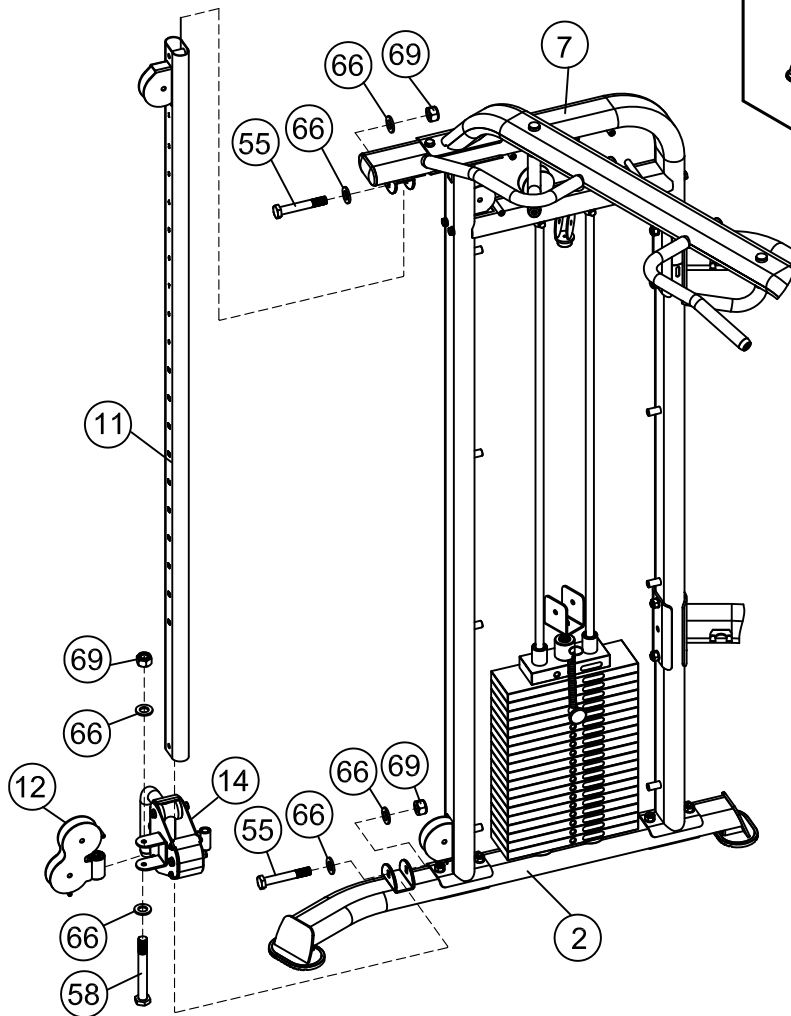
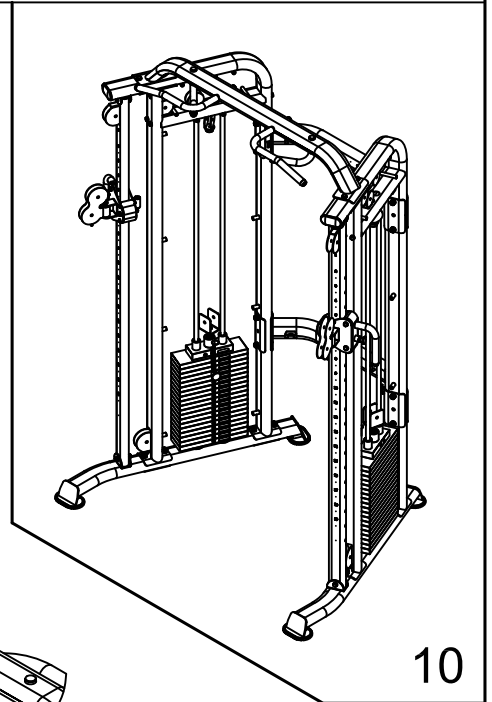
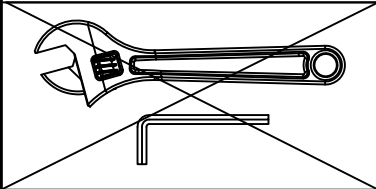

54  × 8 M10×45 57  × 1 M10×75

66   × 18 Φ10 69   × 9 M10

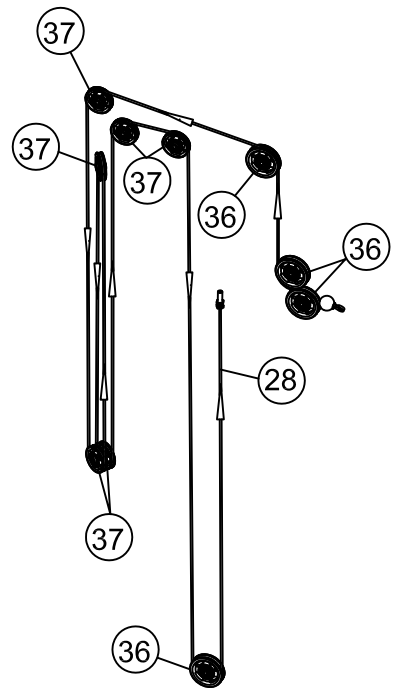
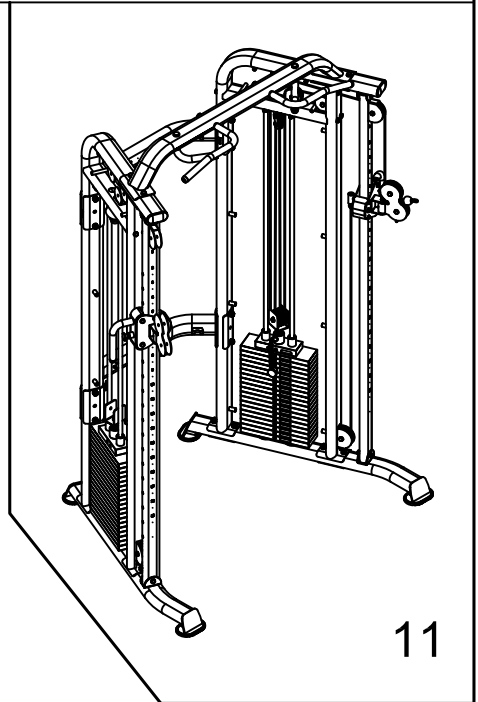
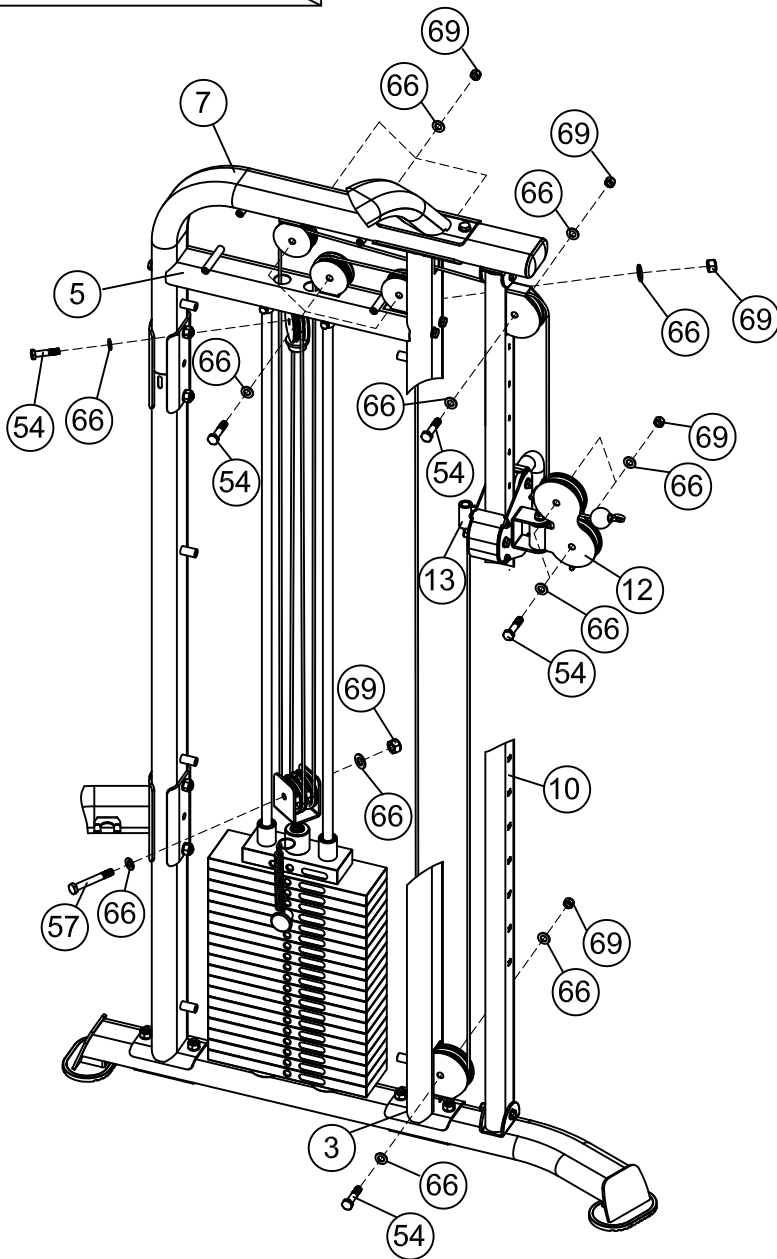
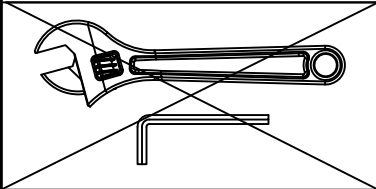

54  × 8 M10×45 57  × 1 M10×75

66   × 18 Φ10 69   × 9 M10

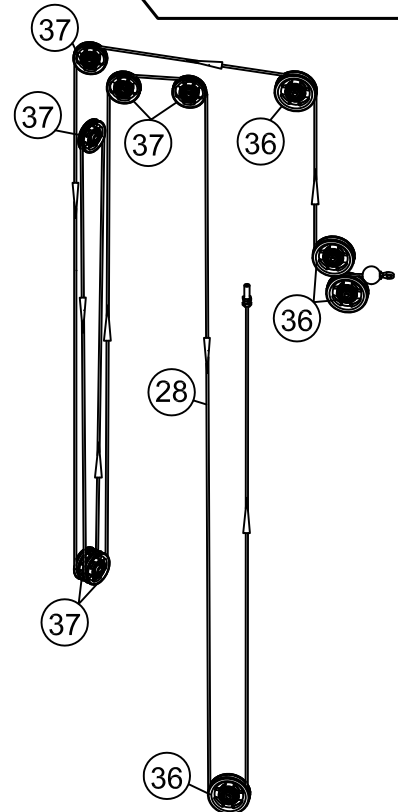
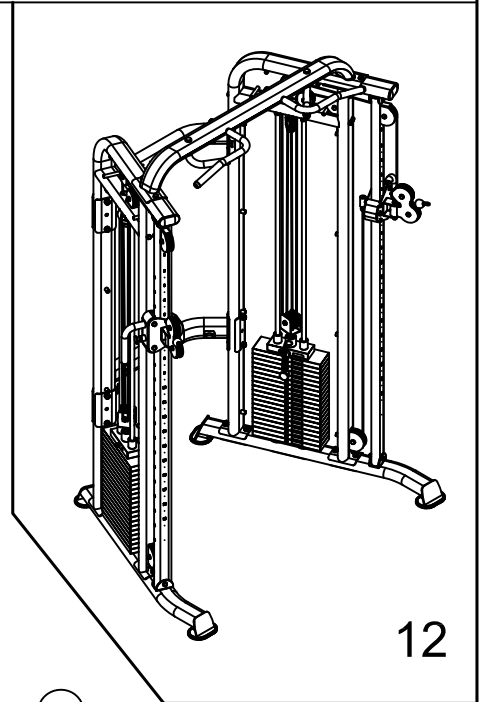
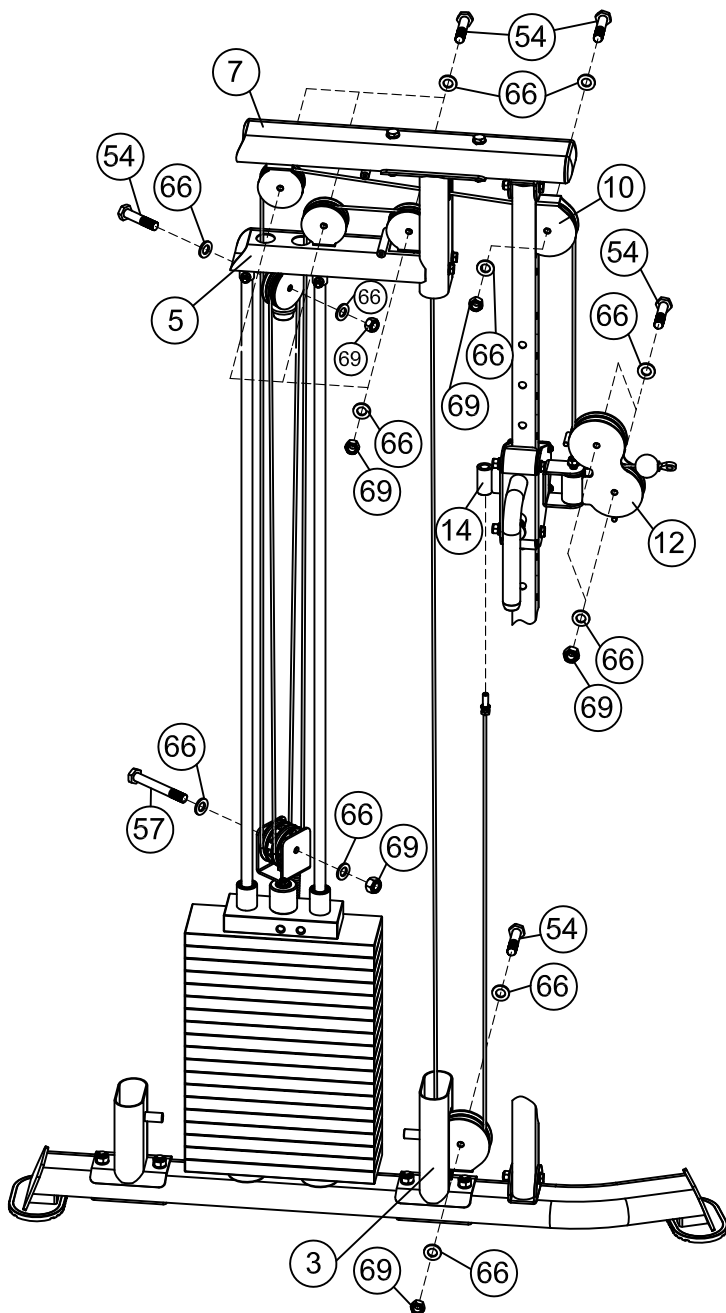
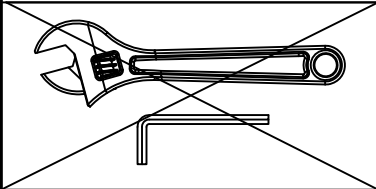

50  ×8 M6×12

51  ×8 M8×16

61  ×8 Φ6

62  ×8 Φ8

64  ×8 Φ6

65  ×8 Φ8

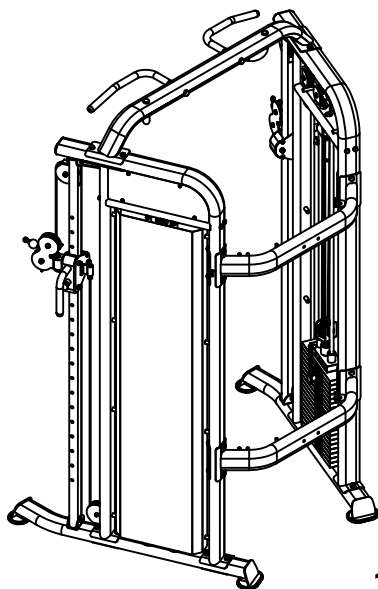
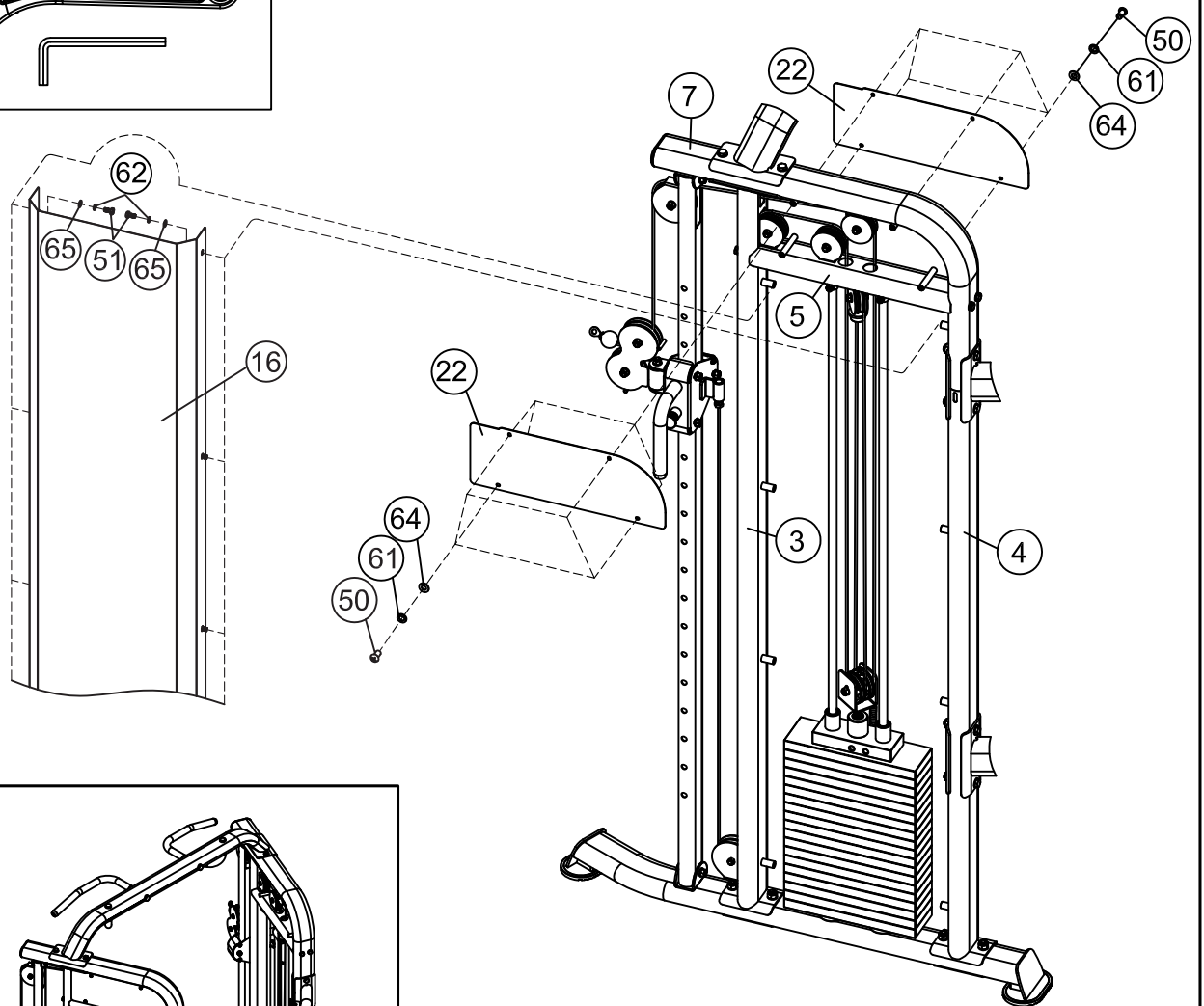
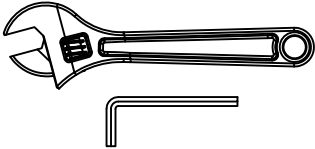

13

50  × 8 M6×12

51  × 8 M8×16

61  | × 8 Φ6

62  | × 8 Φ8

64  | × 8 Φ6

65  | × 8 Φ8

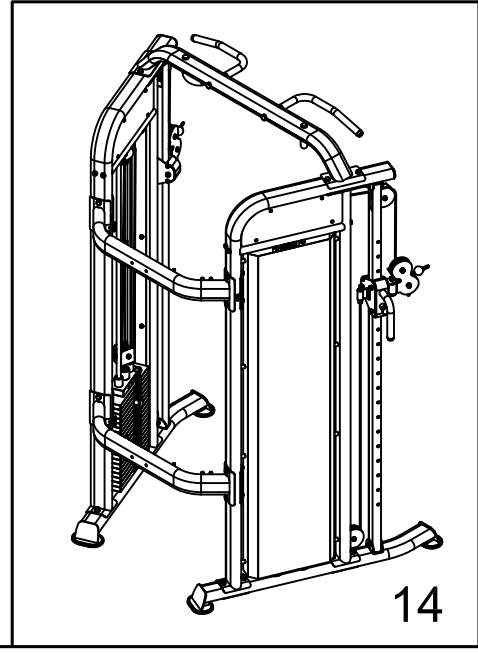
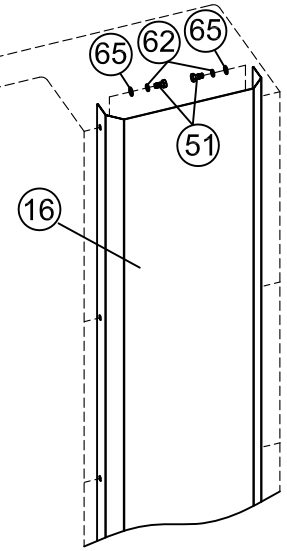
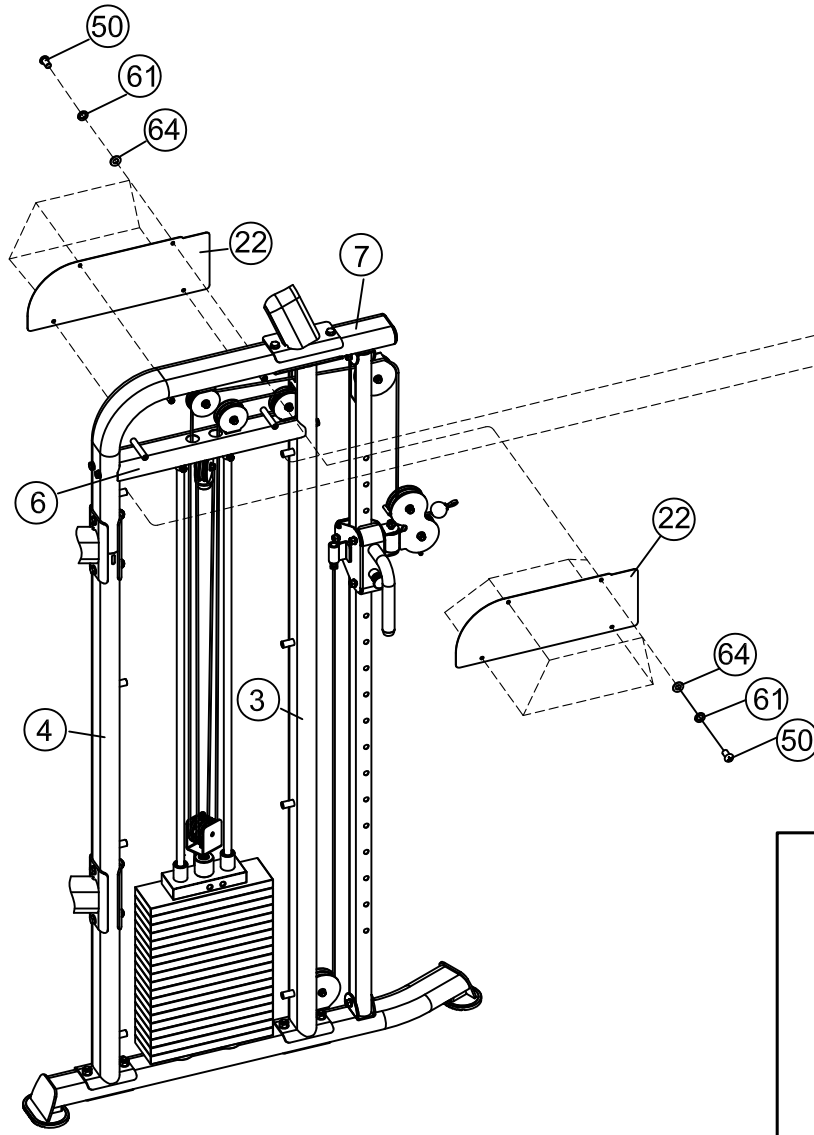
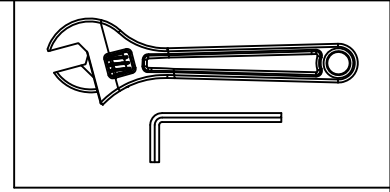

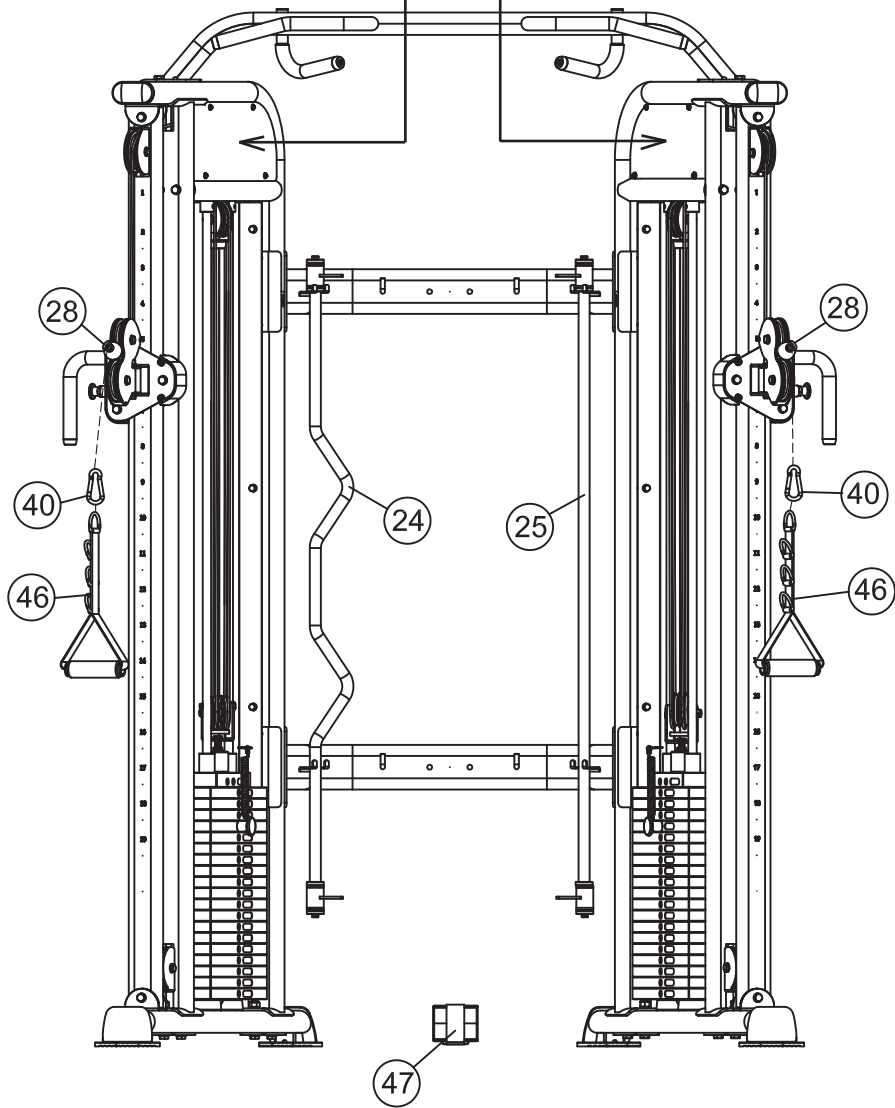
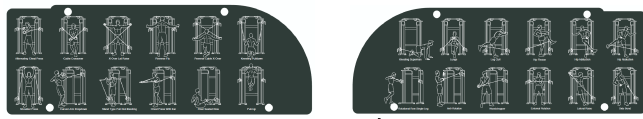
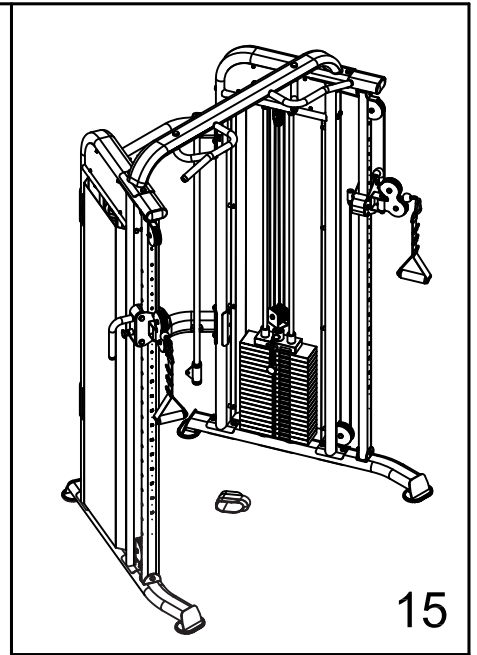

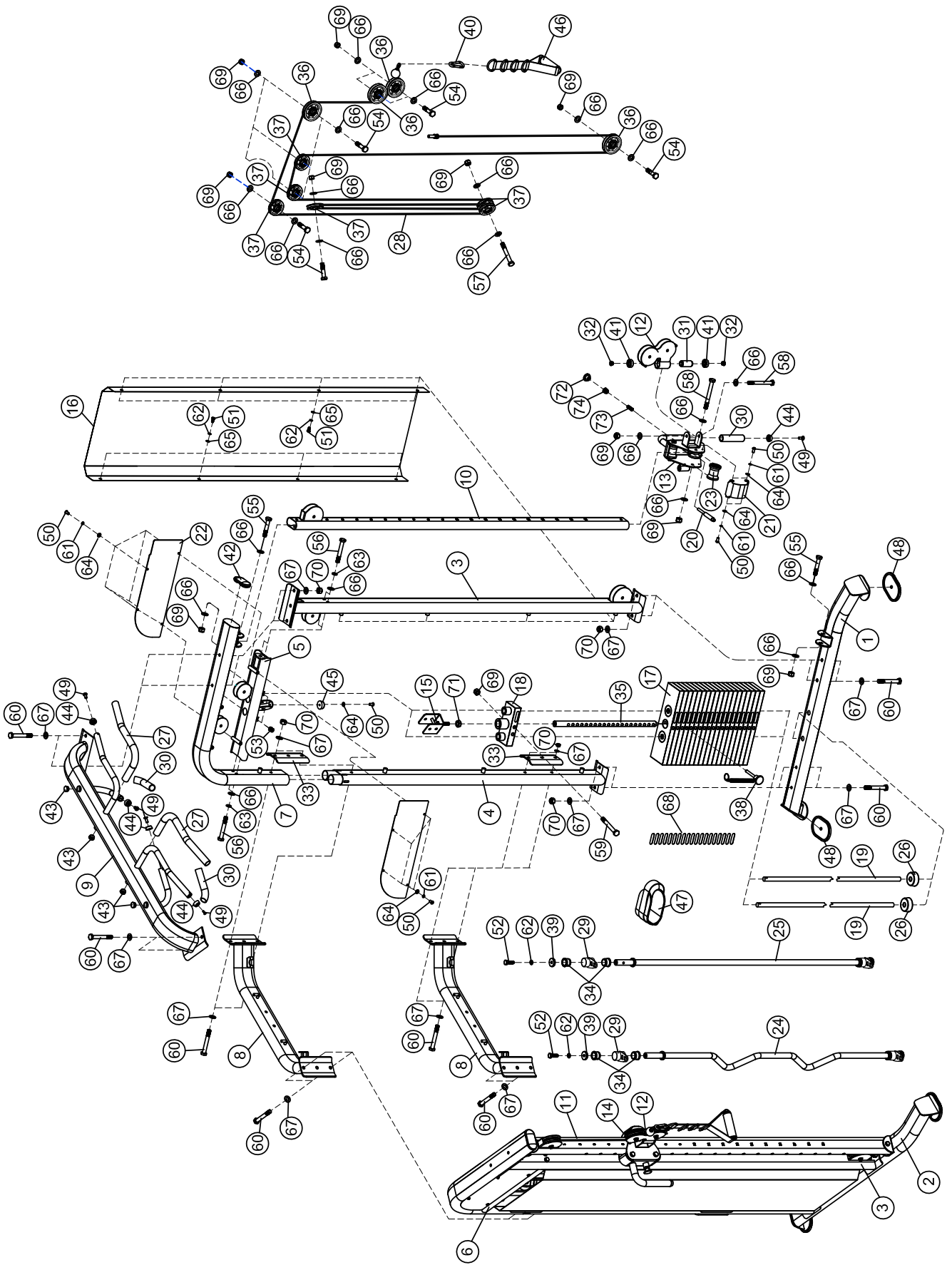

FUNCTIONAL TRAINER X20 PARTS LIST

KEY NO.	DESCRIPTION	SPEC	Q'ty
1	Left Weight Stack Frame		1
2	Right Weight Stack Frame		1
3	Front Support		2
4	Rear Support		2
5	Left Connected Frame		1
6	Right Connected Frame		1
7	Up Frame		2
8	Rear Frame		2
9	Chin-up Bar		1
10	Left Sliding Block		1
11	Rear Sliding Block		1
12	Swivel Pulley Bracket		2
13	Left Sliding Block		1
14	Rear Sliding Block		1
15	Pulley Bracket		2
16	Weight Stack Cover		2
17	Weight Plate		38
18	Selector Stem		2
19	Guide Rod		4
20	pin	φ16×85	2
21	Small wheel cover		2
22	Up Cover		4
23	Wheel		6
24	Lat Bar		1
25	Lat Bar		1
26	Rubber Bumper	φ65×φ60×φ19×25	4
27	Handle Grip	φ30×φ23×470	2
28	Cable		2
29	Bar Handle		4
30	Handle Grip	φ30×φ23×250	4
31	Sleeve	φ18×φ12×39.5	2
32	Bushing	φ21×φ10.5×9.5	4
33	Bracket	180×102×17×5×R25	4
34	Bushing	φ38×φ34×φ27×26	8
35	Selector Rod		2
36	Pulley	φ95	8
37	Pulley	φ72	12

38	Weight Selection Pin		2
39	Bushing	$\phi 38 \times \phi 9 \times 8$	4
40	Hook		2
41	Bearing		4
42	End Cap	PT50×100	2
43	End Cap	$\phi 25$	4
44	Cover Cap	$\phi 30 \times \phi 26 \times 12$	6
45	Rubber Bumper	$\phi 38 \times \phi 7 \times 15$	2
46	Single Handle		2
47	Ankle Strap		1
48	Weight Stack Frame Cap	PT145×95×9	4
49	Sunk Screw	M6×20	6
50	Philips	M6×12	26
51	HEX Bolt	M8×16	16
52	HEX Bolt	M8×25	4
53	Allen Screw	M8×40	4
54	HEX Bolt	M10×45	16
55	HEX Bolt	M10×65	4
56	HEX Bolt	M10×70	8
57	HEX Bolt	M10×75	2
58	HEX Bolt	M10×85	8
59	HEX Bolt	M10×90	2
60	HEX Bolt	M12×80	20
61	Spring washer	6	24
62	Spring washer	8	20
63	Spring washer	10	8
64	washer	6	26
65	washer	8	16
66	washer	10	68
67	washer	12	40
68	Weight Plate Sticker		2
69	Aircraft Nut	M10	32
70	Aircraft Nut	M12	20
71	HEX Nut	M12	2
72	Pin Bushing		2
73	spring		2
74	Pin Cap		2
	Allen Wrench	4#	1